

TOP VIEW
SCALE 1.25

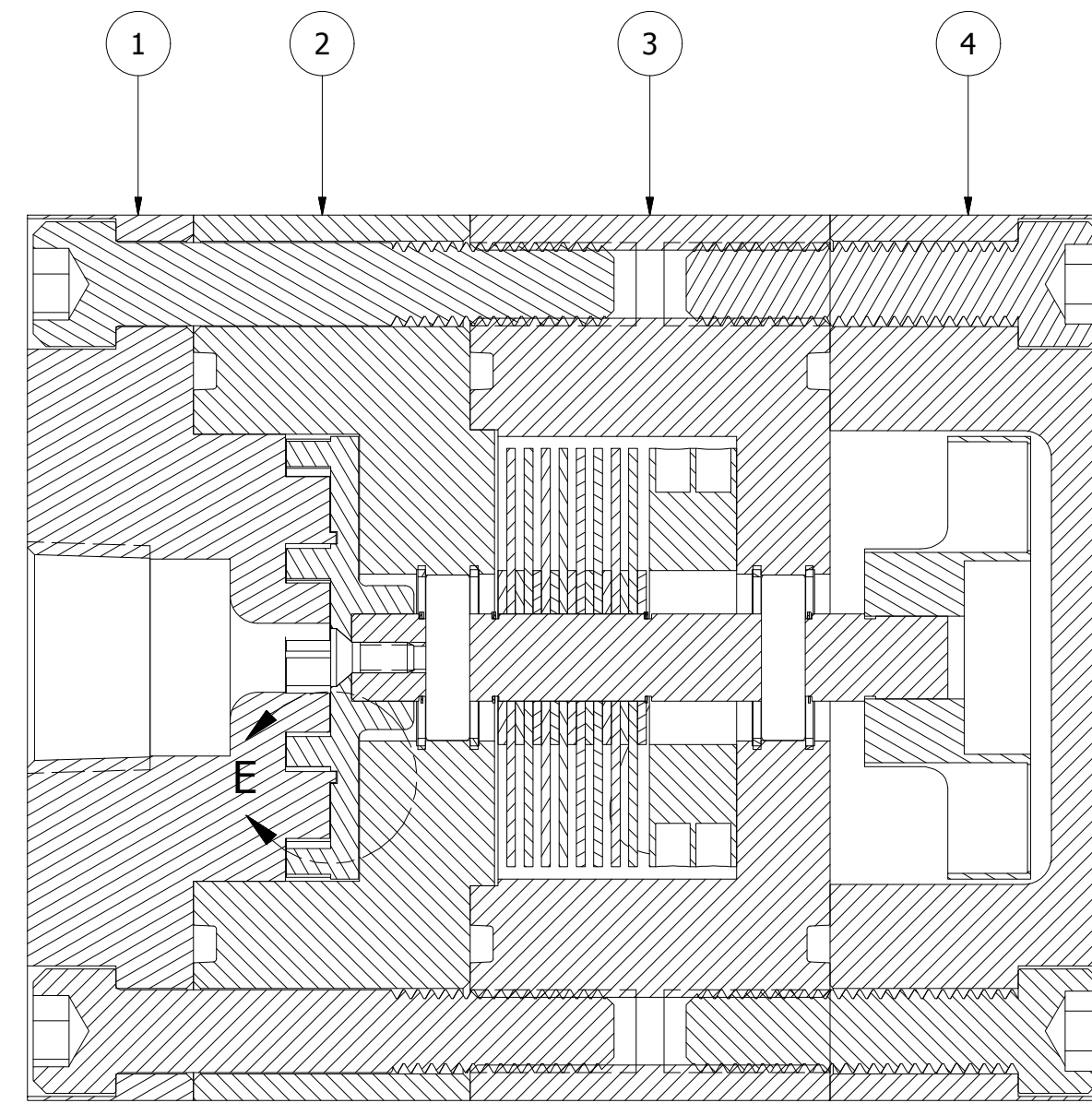

SECTION D-D
SCALE 1.25

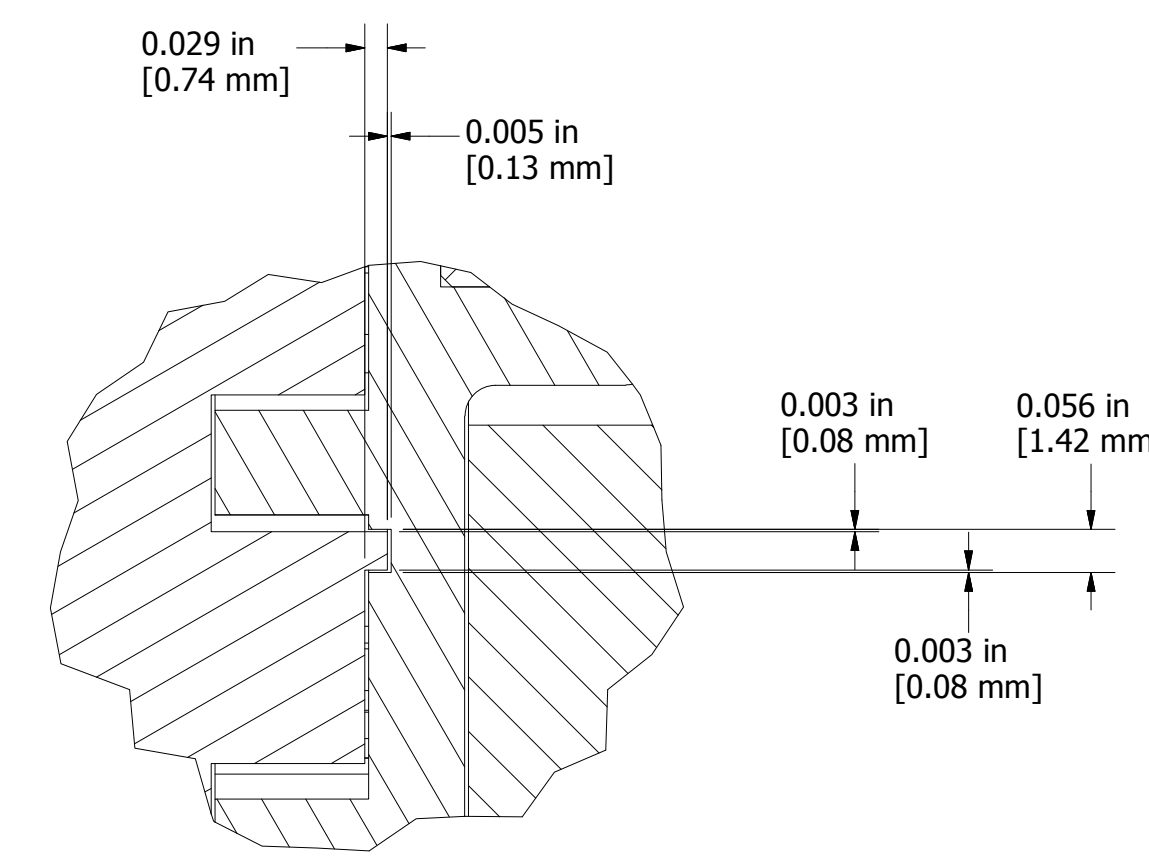

DETAIL E - Labyrinth Seal
SCALE 4 : 1

PARTS LIST			
ITEM	QTY	PART NUMBER	DESCRIPTION
1	1	CO2T_FrontExit_20121023	
2	1	CO2T_FrontBearing_Block_20121023	
3	1	CO2T_LCO2_Mid_Block_20121023	
4	1	CO2T_LCO2_Back_Block_20121023	
5	1	CO2T_Expander_20121023	
6	1	CO2T_LCO2_Tesla_Rotor_20121023	
7	1	CO2T_Pump_Shaft_20121023	
8	1	CO2T_LCO2_Cav_Disc_20121023	
9	1	CO2T-LCO2_Mag_Hub_20121023	
10	4	91482A260 Snap Ring	McMaster Carr P/N 91482A260 or equivalent
11	4	91650A340 SpiroLoc Retainer	McMaster Carr P/N 91650A340 or equivalent
12	2	10x19x5 mm Full ceramic angular bearing	Full ceramic angular bearing
13	4	ANSI B18.3 - 10-32 UNF - 0.5 HS HCS	Hexagon Socket Head Cap Screw
14	1	ANSI B18.3 - 6-40 UNF x 0.375	Hexagon Socket Flat Countersunk Head Cap Screw
15	8	MIL Spec Alloy Steel Socket Head Cap Screw Cadmium Pldd - 3/8"-16 Thrd, 1-1/2" L, MS 16997-101	McMaster Carr P/N - 92562A352 or equivalent
16	8	MIL Spec Alloy Steel Socket Head Cap Screw Cadmium Pldd, 3/8"-16 Thrd, 2-1/4" L, MS16997-104	McMaster Carr P/N - 92562A361 or equivalent

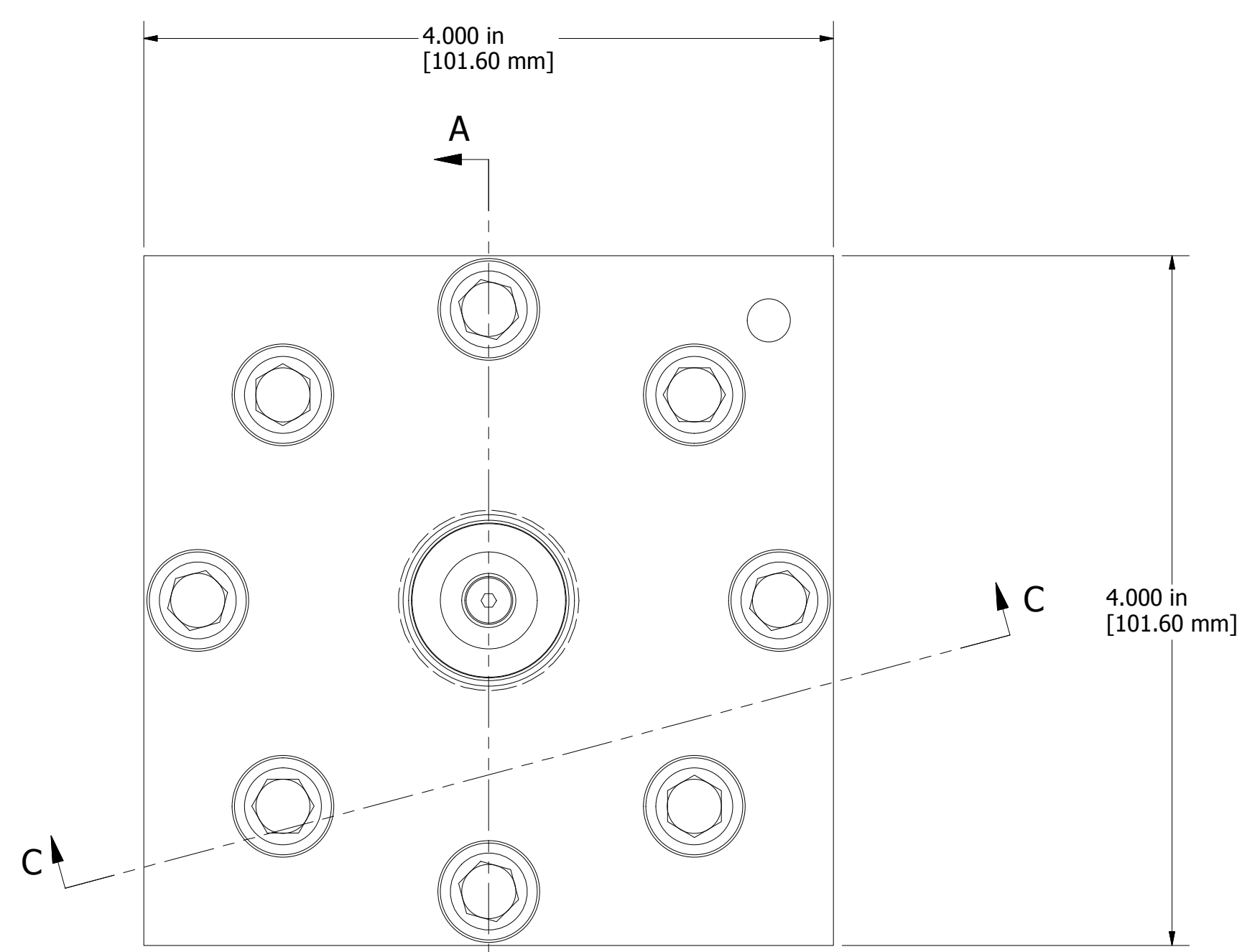

FRONT VIEW
SCALE 1.25

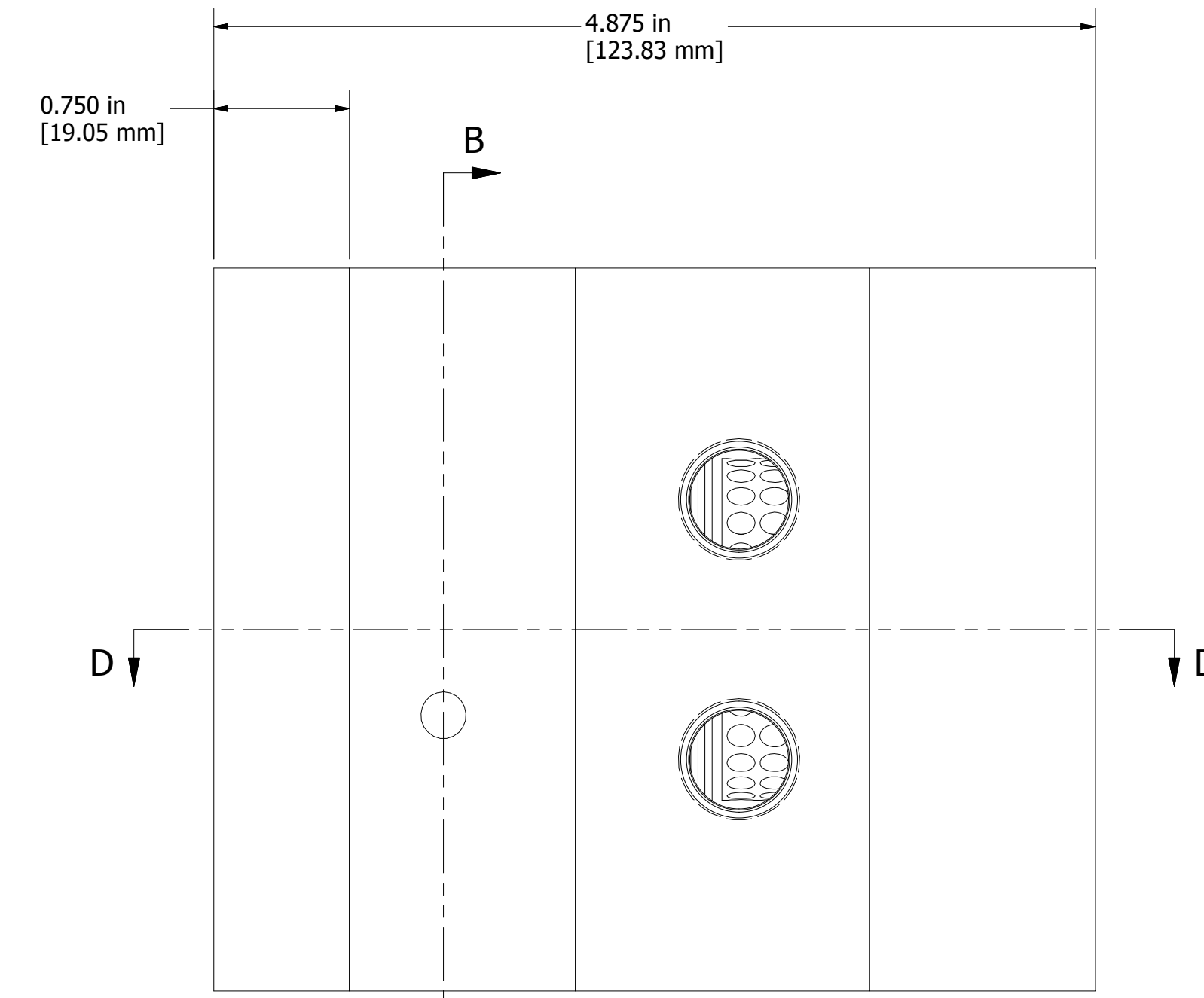

SIDE VIEW
SCALE 1.25

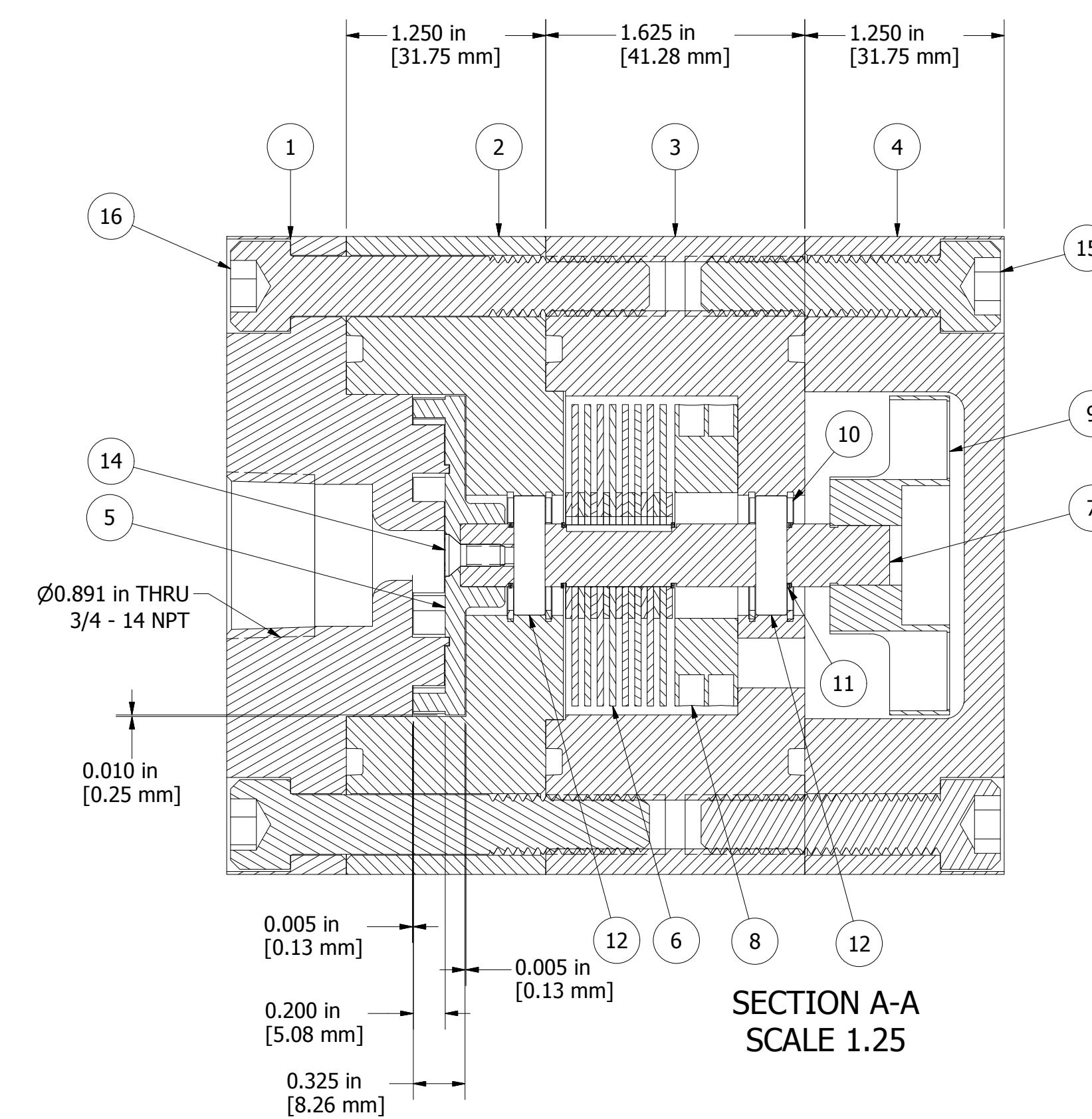

SECTION A-A
SCALE 1.25

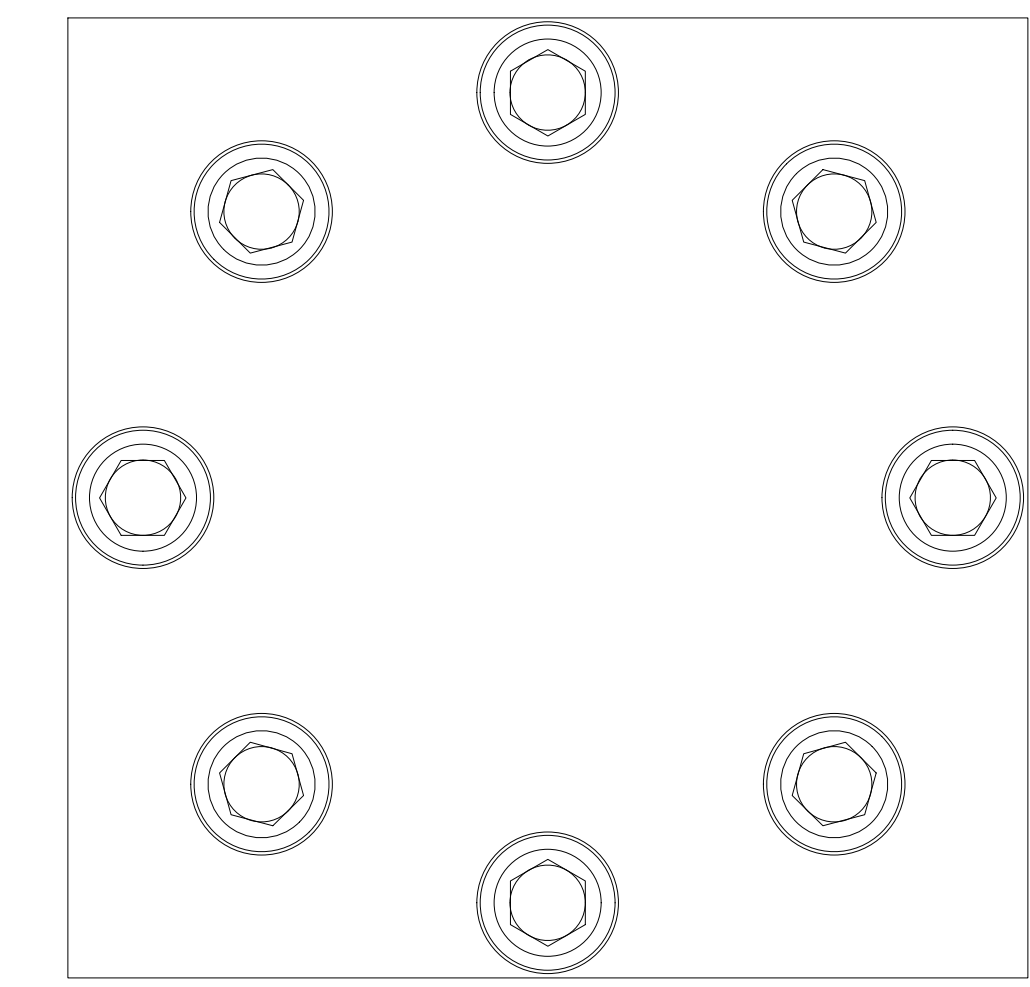

BACK VIEW
SCALE 1.25

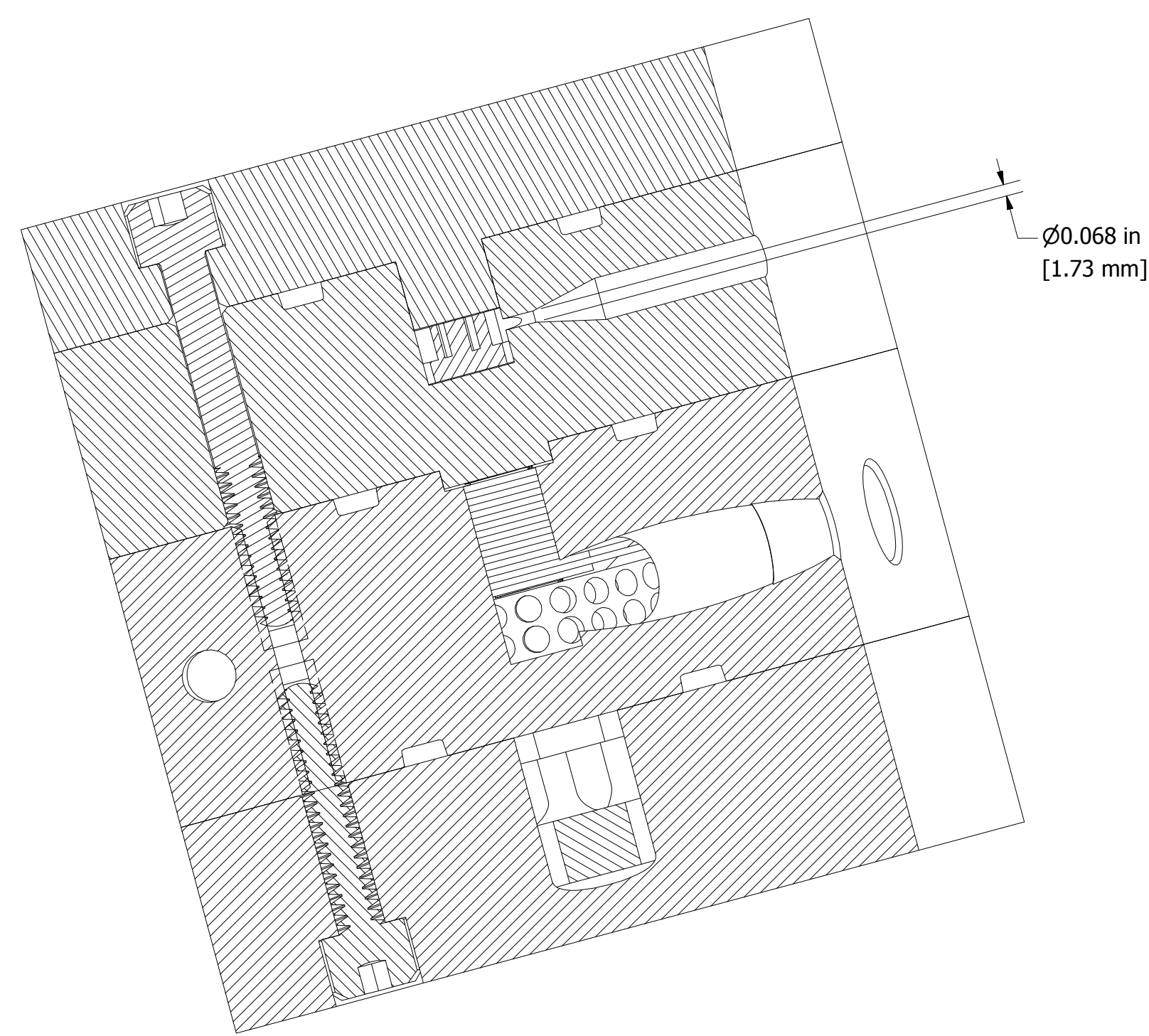

SECTION C-C
SCALE 1.25

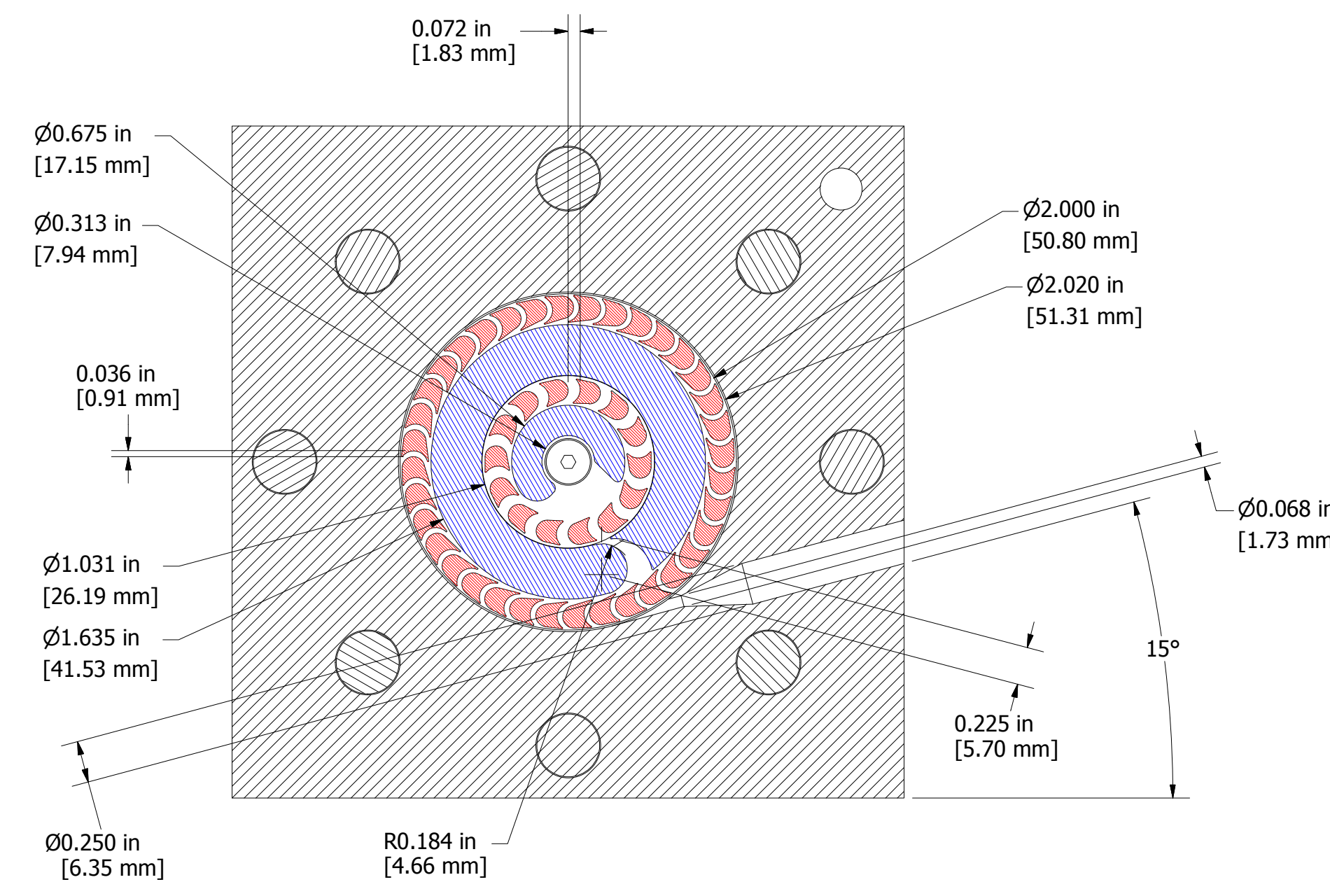

SECTION B-B
SCALE 1.25

Copyright 2012 - Infinity Turbine, LLC

Turbine/Housing Covered Under
Patents: 7146999, 7726331

PROPRIETARY AND CONFIDENTIAL
THE INFORMATION CONTAINED IN THIS DRAWING IS THE SOLE PROPERTY OF INFINITY TURBINE, LLC. ANY REPRODUCTION IN PART OR AS A WHOLE WITHOUT THE WRITTEN PERMISSION OF INFINITY TURBINE, LLC IS PROHIBITED.

UNLESS OTHERWISE NOTED:	DRAWN	DATE
CONSIDERING ARE IN INCHES	EGD	11/9/2012
TOLERANCES	CHECKED	
FACTORY	QA	
INSPECTION	INSPECTION	
THIS PLACE DESIGN, I.E.E.	NFG	
THREE PLACE DECIMAL, I.E.E.D.		
INTERPRET GEOMETRIC TOLERANCES PER:	APPROVED	
ANSI Y14.5		
DATE:		
SEE PART DRAWINGS		
N/A		
DO NOT SCALE DRAWING		

TITLE	DATE	REV
CO2T - LCO2 Turbine & Pump Assembly		
CO2T - LCO2 Turbine & Pump Assembly		
CO2T-LCO2_Pump_Assembly_20121023		
SCALE		
SHEET 1 OF 1		

INFINITY TURBINE