

ITEM NO.	PART NUMBER	DESCRIPTION	QTY.
1	2013 ITmicro Front exit block		1
2	2013 ITmicro Radial Impeller noHex		1
3	2013 ITmicro bearing block		1
4	2013 ITmicro front flange		1
5	2013 ITmicro mag coupler turbine side		1
6	2013 ITmicro back block		1
7	3-8-16--2--1-4in Double End Stud		8
8	3-8-16--1--3-4in Double End Stud		8
9	2013 ITmicro Radial Shaft		1
10	serrated flange nut 95922A130		16
11	DIN 625 SKF - SKF 61800		2
12	2013 ITmicro bearing spacer mid		1
13	2013 ITmicro bearing spacer back		1

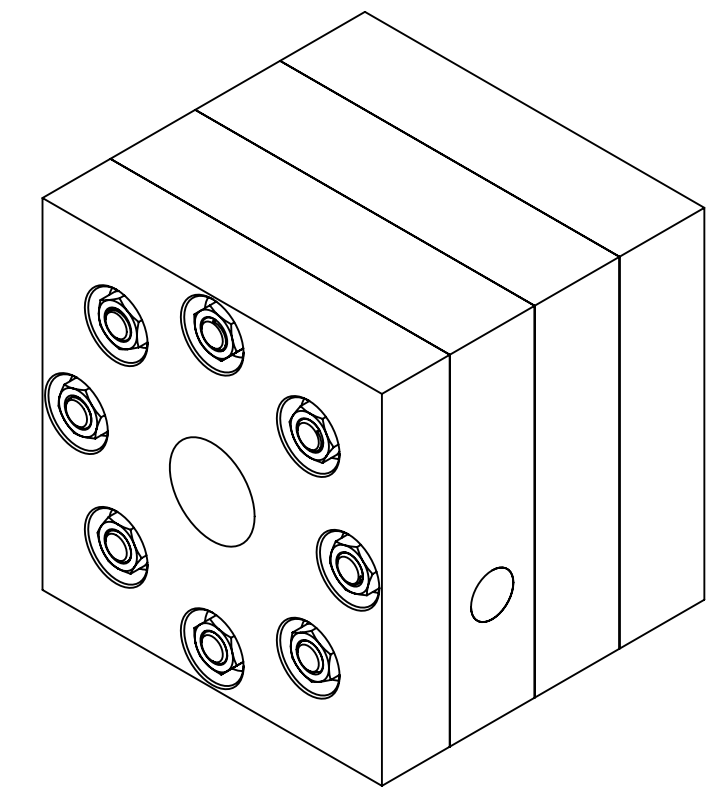

3D VIEW
SCALE 1 : 2

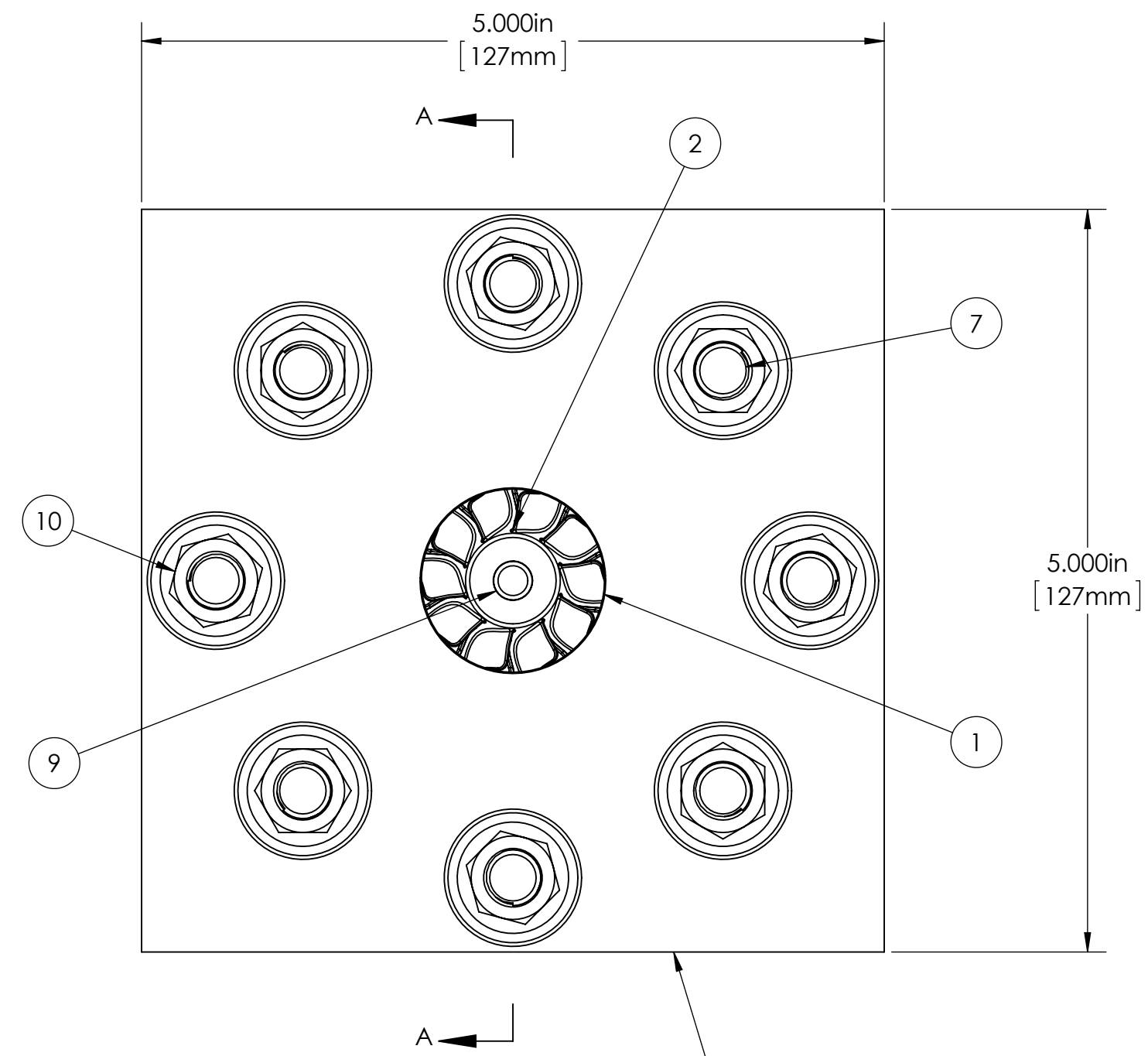

FRONT VIEW
SCALE 1:1

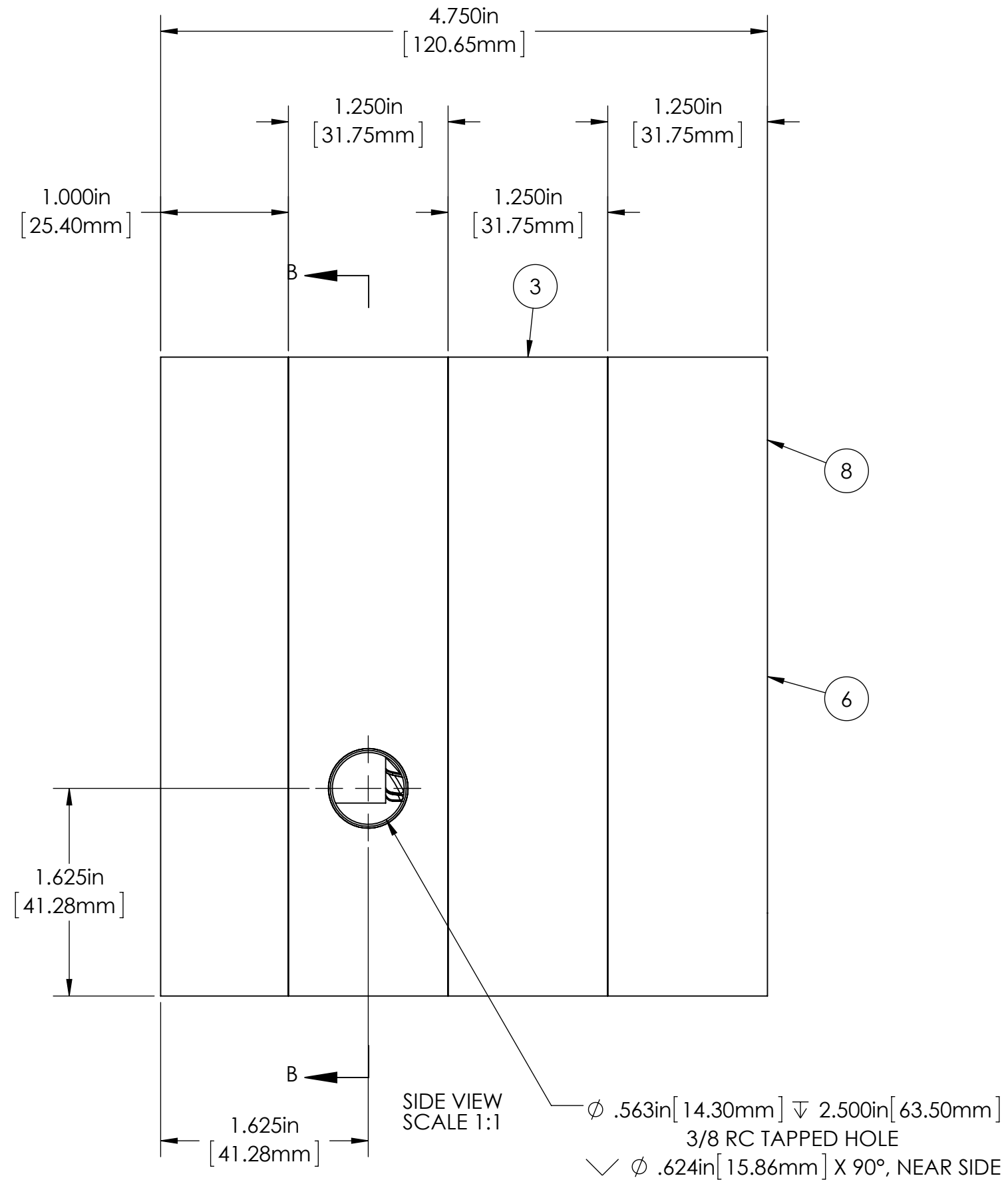

SIDE VIEW
SCALE 1:1

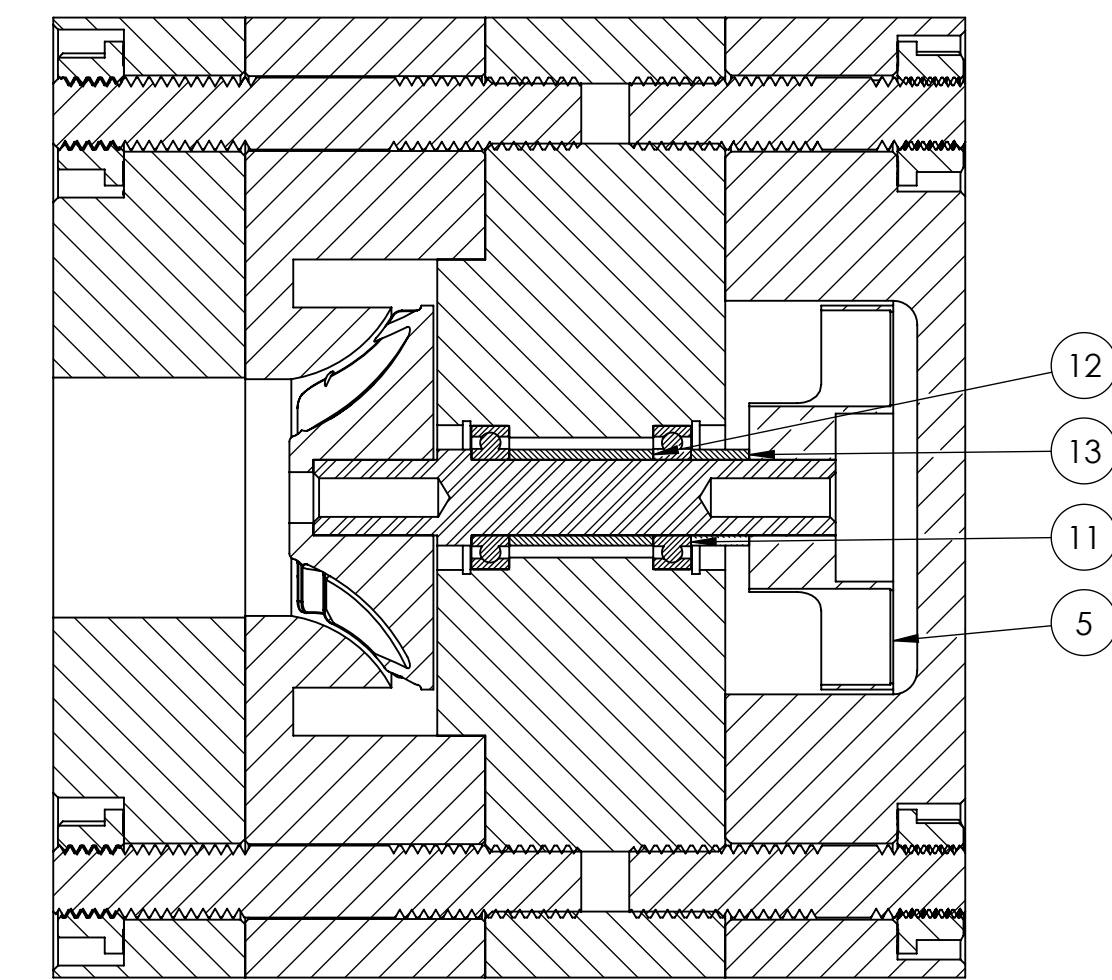

SECTION A-A



BOTTOM VIEW
SCALE 1:1

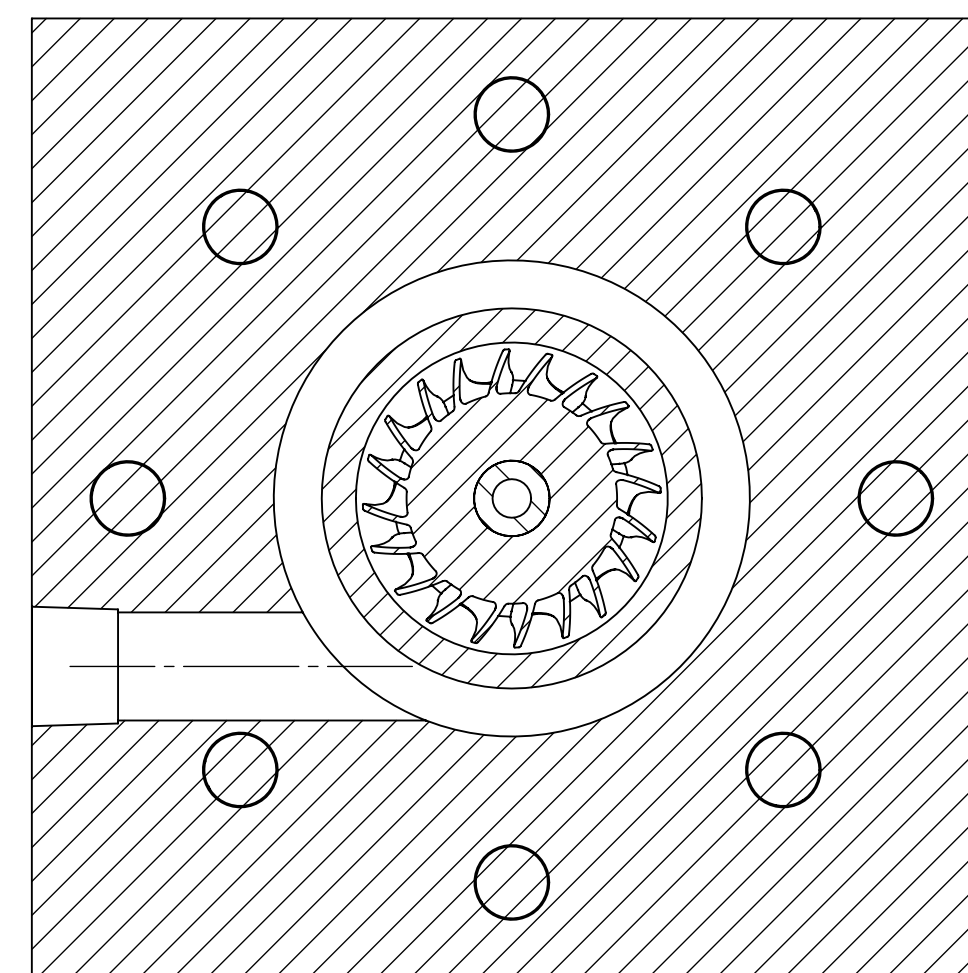

SECTION B-B

PROPRIETARY AND CONFIDENTIAL
THE INFORMATION CONTAINED IN THIS DRAWING IS THE SOLE PROPERTY OF INFINITY TURBINE LLC. ANY REPRODUCTION IN PART OR AS A WHOLE WITHOUT THE WRITTEN PERMISSION OF INFINITY TURBINE LLC IS PROHIBITED.

UNLESS OTHERWISE SPECIFIED:		DATE	BY
DRAWN	Eddie	01/20/2013	
CHECKED			
ENG APPR.			
MFG APPR.			
Q.A.			
COMMENTS:			
NEXT ASSY	USED ON	FINISH	
APPLICATION			

INFINITY TURBINE

TITLE: 2013 ITmicro Radial assy

SIZE DWG. NO. REV
D 2013 ITmicro Radial assy

SCALE: 1:1 WEIGHT: SHEET 1 OF 1

REV
D 2013 ITmicro Radial assy