

| ITEM | | PARTS LIST | | DESCRIPTION |
|------|-----|---|--|--|
| ITEM | QTY | PART NUMBER | | DESCRIPTION |
| 1 | 1 | 20120111_ITmini_Mid_Block | | |
| 2 | 1 | 20111214_ITmini_Front_BlockRevB_Revised | | |
| 3 | 1 | 20111208_ITmini_Back_Block | | |
| 4 | 1 | 20111208_ITmini_Maj_Hub | | |
| 5 | 1 | 20111208_ITmini_3-In_pipe_part | | |
| 6 | 2 | 10x19x5 mm Full ceramic angular bearing | | Full ceramic angular contact thrust bearings |
| 7 | 1 | JIS B 1177 Cup Point - M5 x 8 | | Hexagon Socket Set Screw - Cup Point |
| 8 | 6 | ANSI B18.3 - 10-32 UNF - 1.75 HS HCS | | Hexagon Socket Head Cap Screw |
| 9 | 6 | ANSI B18.3 - 10-32 UNF - 1.25 HS HCS | | Hexagon Socket Head Cap Screw |
| 10 | 1 | 20111206_ITmini_Blades | | |
| 11 | 1 | 20120116_ITmini_Adapter_Block_2 | | |
| 12 | 1 | 20111217_ITmini_ShaftRevB | | |
| 13 | 4 | 91482A260 snap ringRevB_91482A260 | | McMaster Carr P/N 91482A260 or equivalent |
| 14 | 4 | 91650A340 spirolocRevB_91650A340 | | McMaster Carr P/N 91650A340 or equivalent |

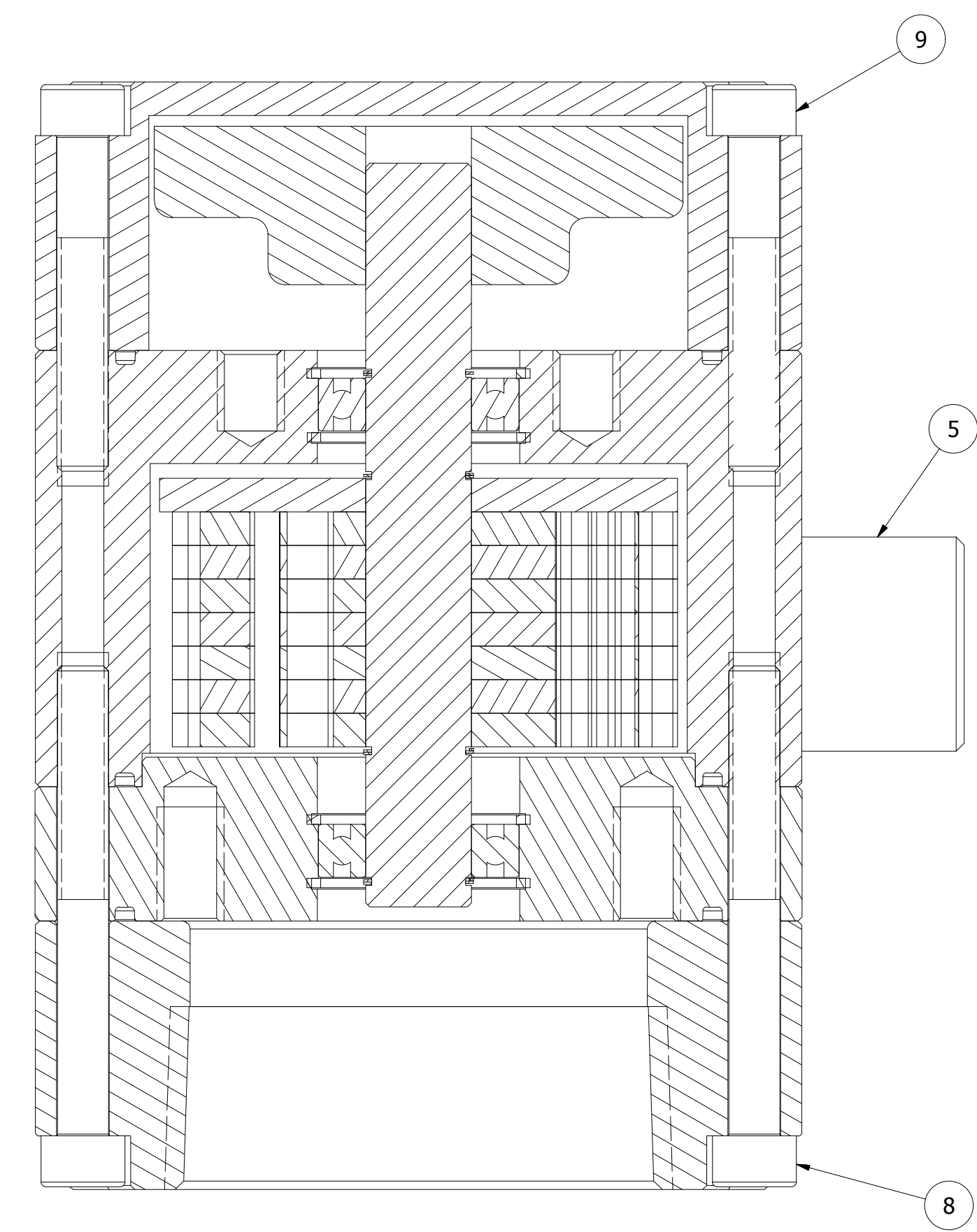

SECTION B-B
SCALE 2 : 1

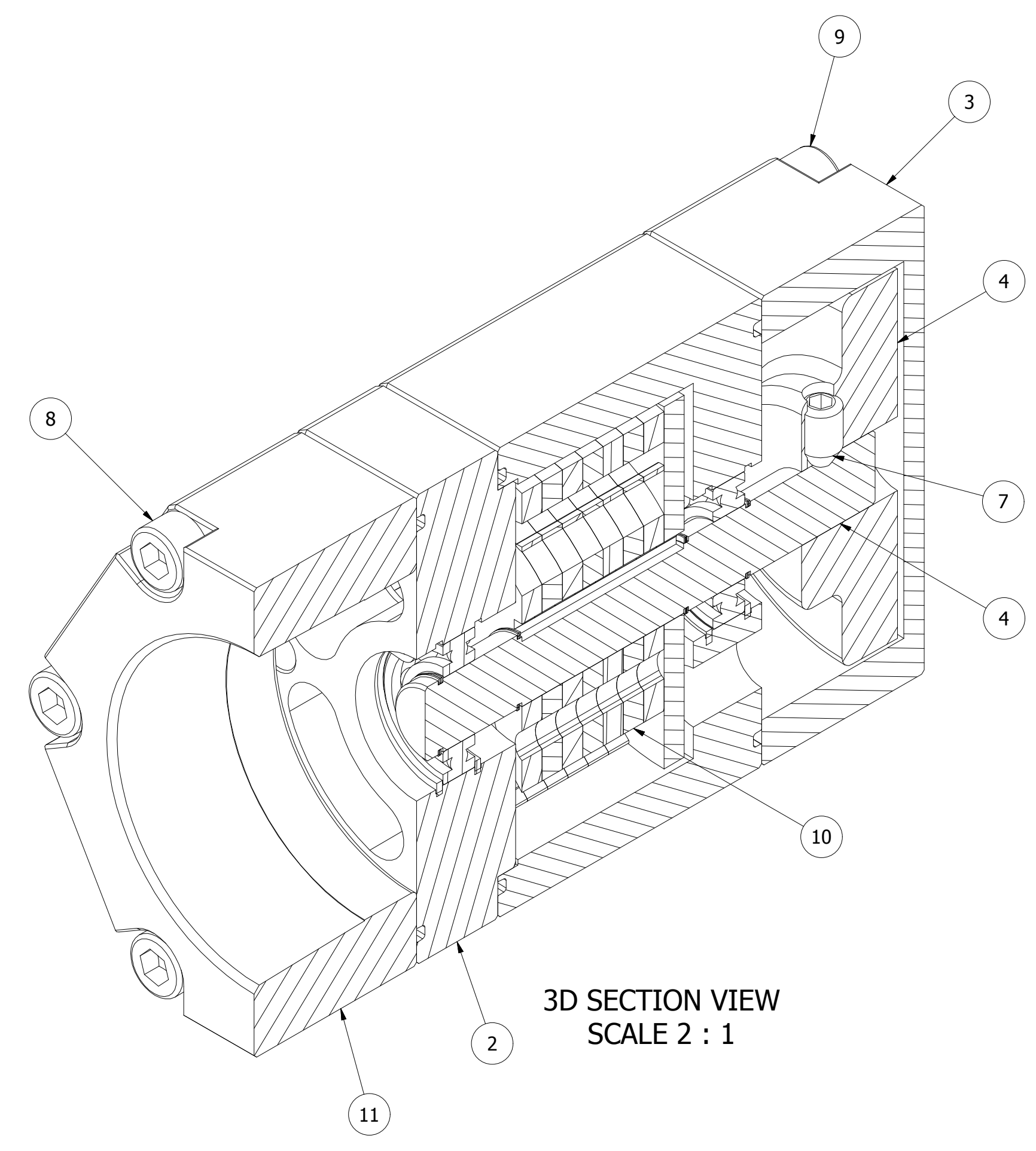

3D SECTION VIEW
SCALE 2 : 1

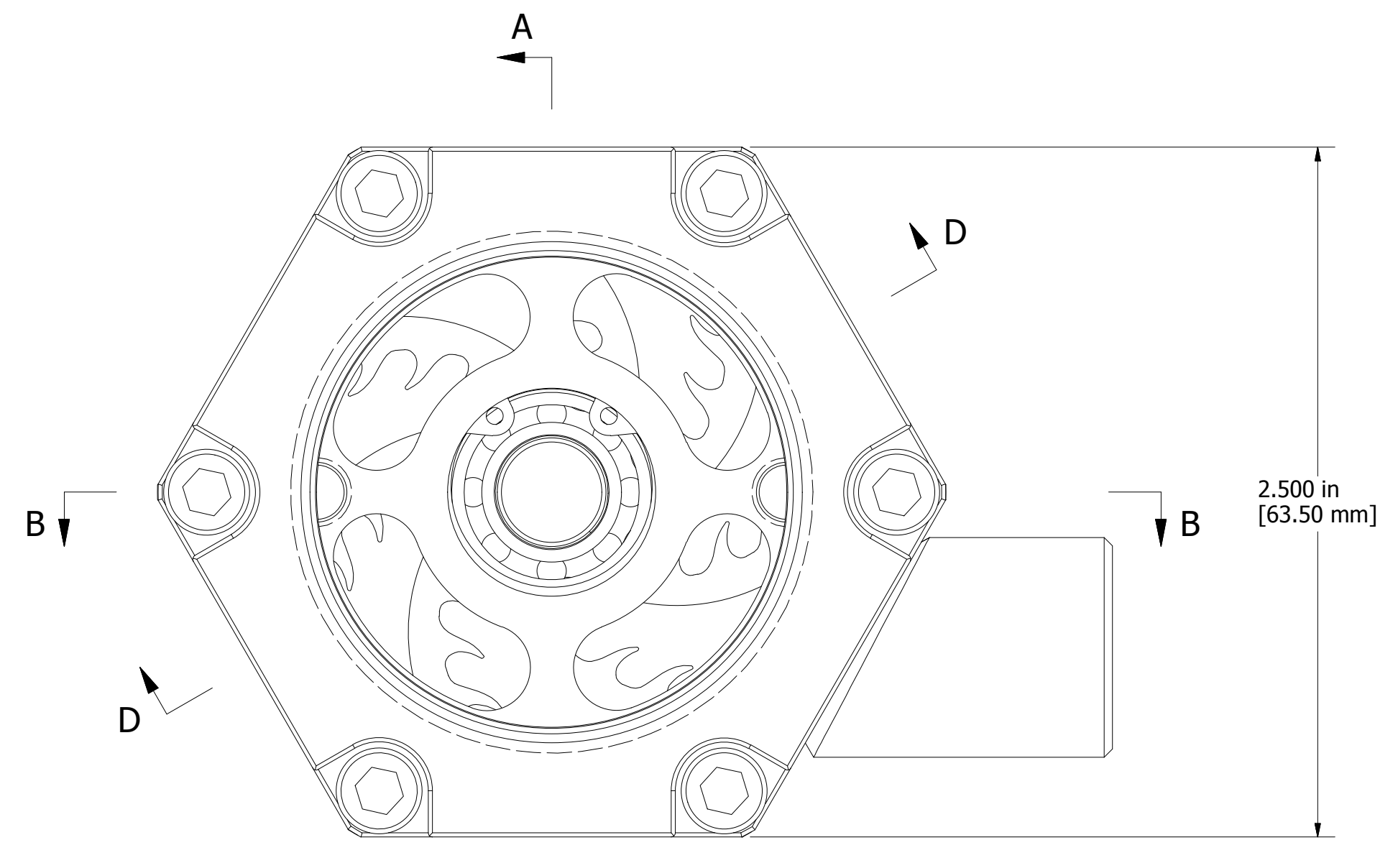

FRONT VIEW
SCALE 2 : 1

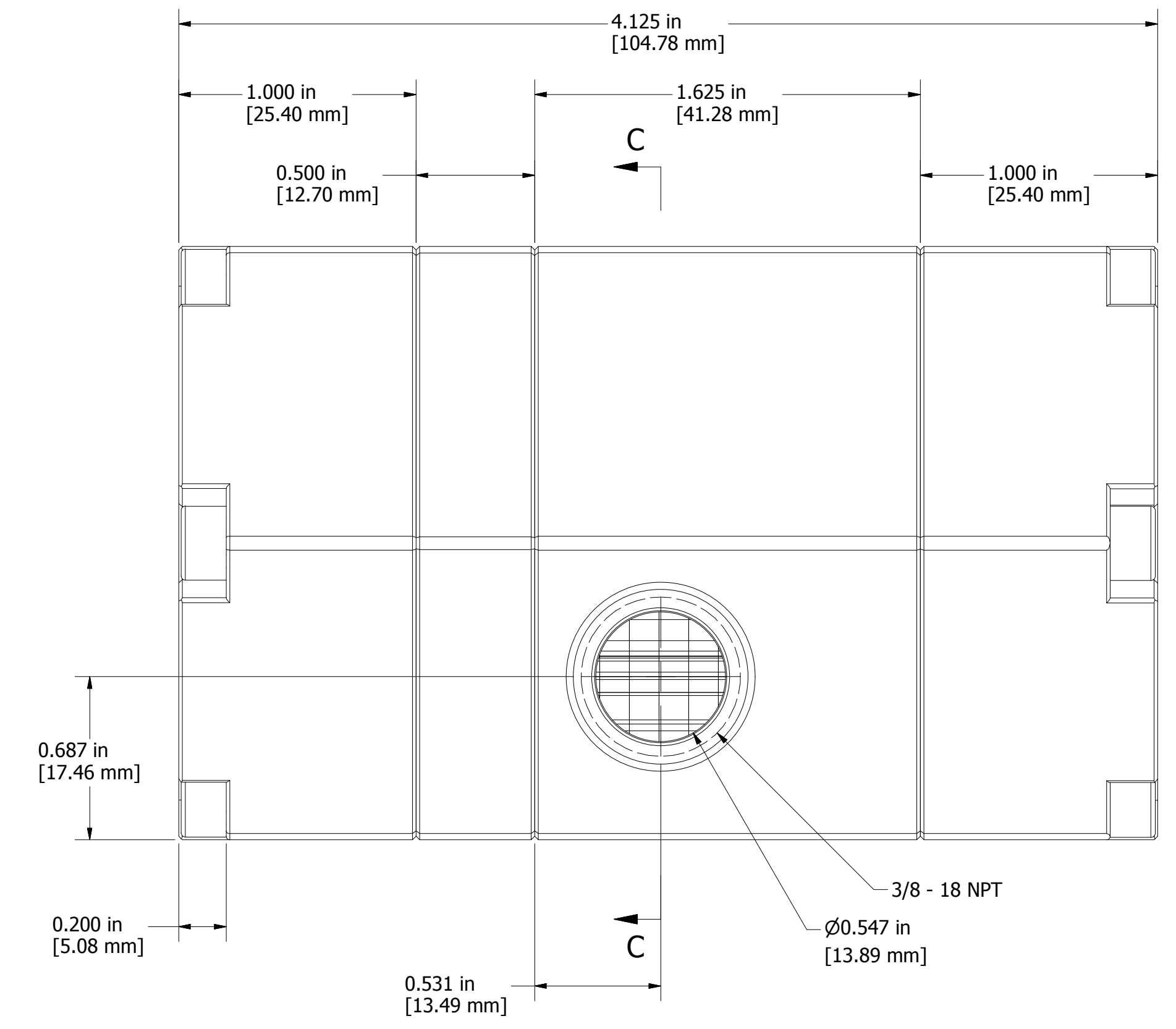

SIDE VIEW
SCALE 2 : 1

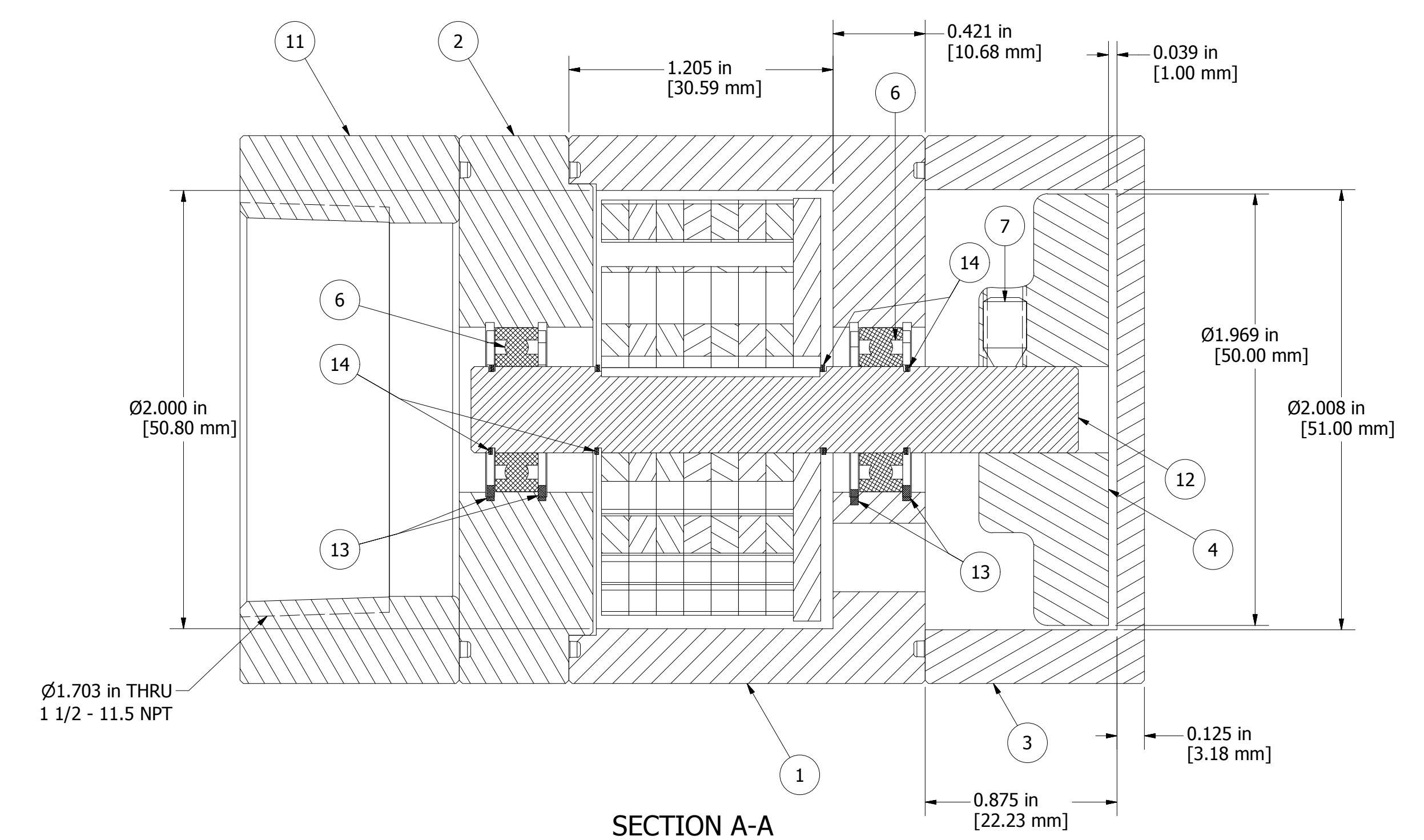

SECTION A-A
SCALE 2 : 1

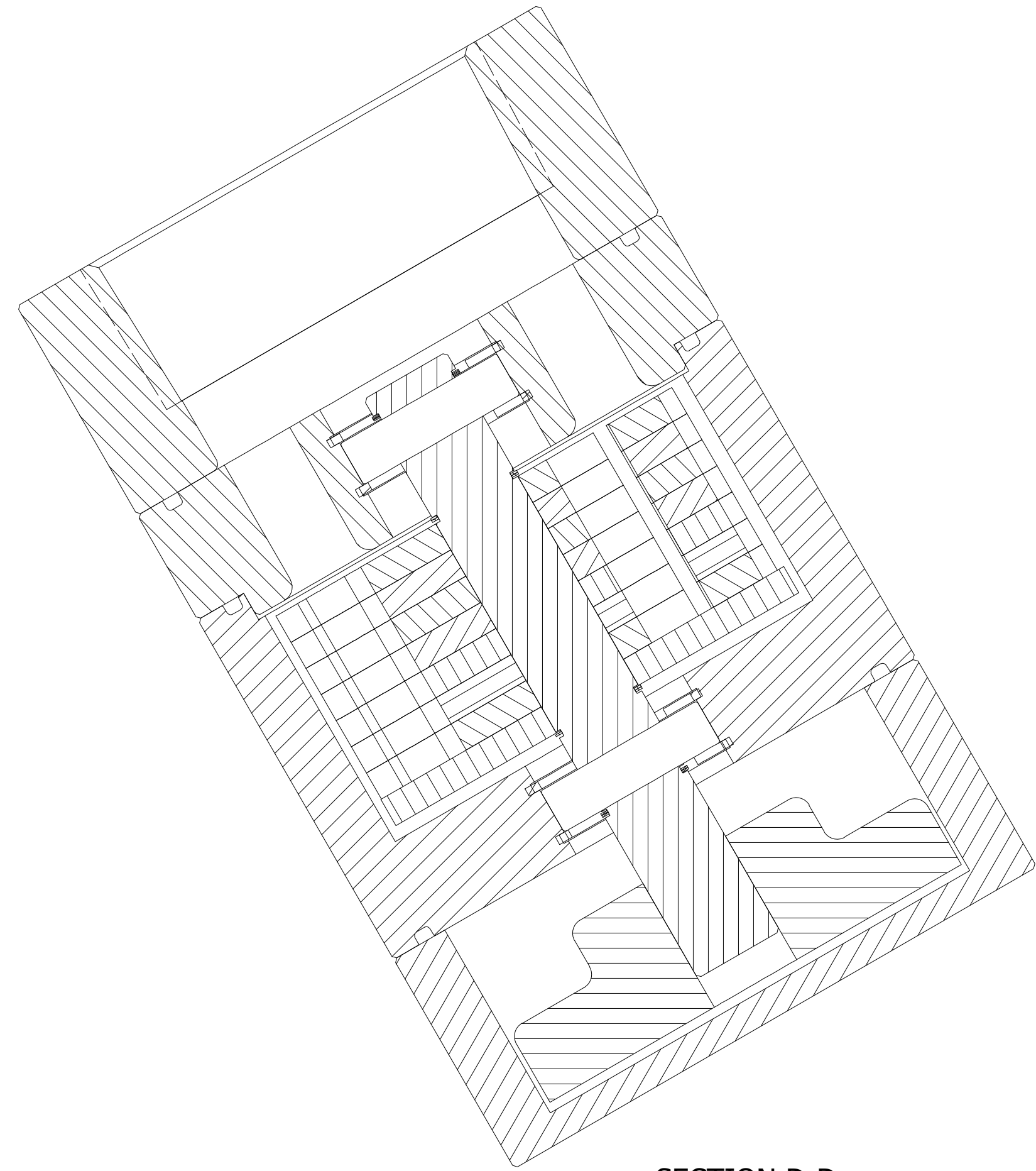

SECTION D-D
SCALE 2 : 1

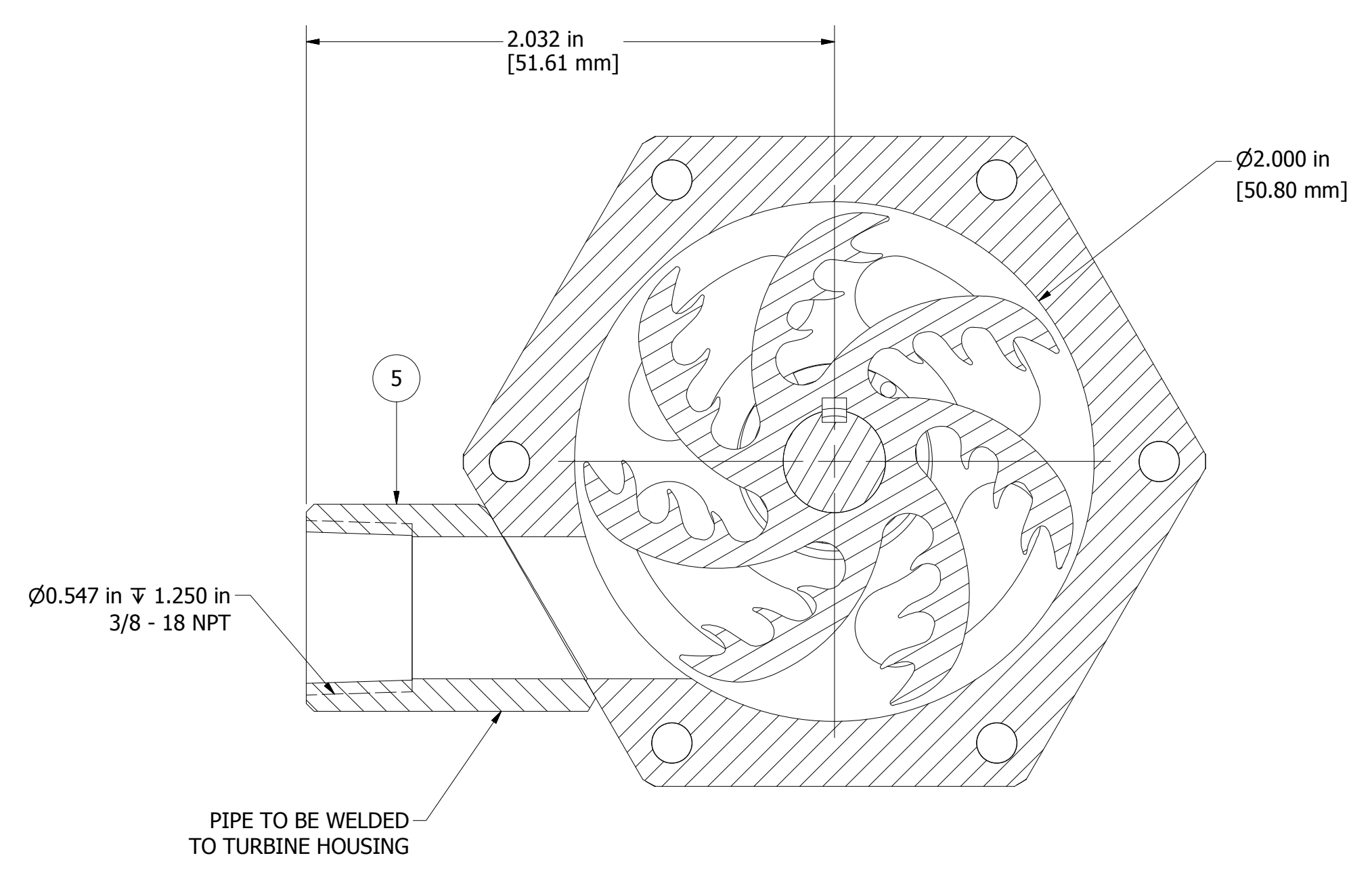

SECTION C-C
SCALE 2 : 1

Copyright 2012 - Infinity Turbine, LLC

Turbine/Housing Covered Under Patents: 7146999, 7726331

PROPRIETARY AND CONFIDENTIAL
THE INFORMATION CONTAINED IN THIS DRAWING IS THE SOLE PROPERTY OF INFINITY TURBINE, LLC. ANY REPRODUCTION IN PART OR AS A WHOLE WITHOUT THE WRITTEN PERMISSION OF INFINITY TURBINE, LLC IS PROHIBITED.

| | | |
|--|----------|-----------|
| UNLESS OTHERWISE NOTED: | DRAWN | 1/19/2012 |
| CONSIDERING ARE IN INCHES | CHECKED | |
| TOLERANCES | QA | |
| FACTORY | NFG | |
| INSURANCE WORK & E.E. BOND & TRIP PLACE ORDERING & E.E. BOND | | |
| THREE PLACE DECIMALS & 0.001 | | |
| INTERNET SPECIFIC: ANSI Y14.5 | APPROVED | |
| PARTS LIST: See part drawings | | |
| FINISH: N/A | | |
| DO NOT SCALE DRAWING | | |

| | |
|-------|---------------------------|
| TITLE | ITmini - Turbine Assembly |
| DATE | 20111209_ITmini_assembly |
| SCALE | |
| SHEET | 1 OF 1 |