

2X Ø .313in [7.94mm] ± 1.060in [26.92mm]
 3/8-16 UNC - 2B ± .750in [19.05mm]
 ✓ Ø .380in [9.65mm] X 90°, NEAR SIDE

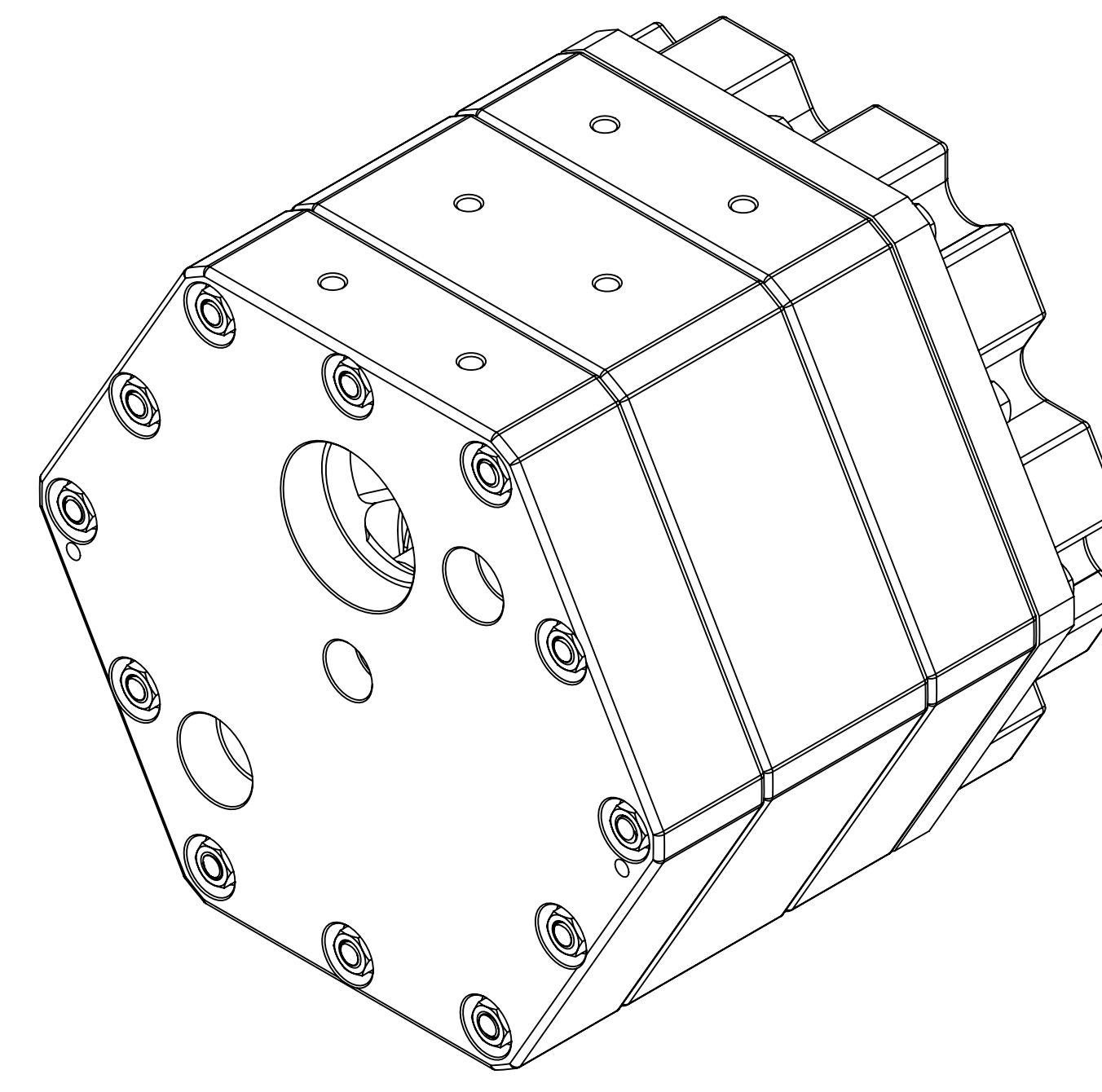

ISOMETRIC VIEW
 SCALE: 1:2

ITEM NO.	PART NUMBER	DESCRIPTION	QTY.
1	20130217_ITR_Rotor_Housing		1
2	20130213_ITR_Rotor		1
3	20130217_ITR_Bearing_Block		1
4	20130217_ITR_Front_Block		1
5	20130217_ITR_Back_Block		1
6	20130217_ITR_Coupler_Turbine-side		1
7	20130217_ITR_Shaft		1
8	20130217_ITR_Bearing_Spacer-A		1
9	20130217_ITR_Bearing_Spacer-B		1
10	DIN 628 SKF - SKF 7303 BE		2
11	99142A580 snap ring	Retainer Ring - McMaster Carr P/N - 99142A580 or equivalent	1
12	18-8 Stainless Steel Spacing Stud 3/8-13 x 5-1/2 L O-ail Thrd Lengths	Black-Oxide Steel Spacing Stud 3/8"-1.6Sz, 5-1/2" L O-ail, 1-1/4" & 1-1/4" Thrd Lengths - McMaster Carr P/N 90281A646 or equivalent	12
13	serrated flange nut 95922A130_95922A130	Serrated Flange Nut - McMaster Carr P/N - 95922A130 or equivalent	24
14	18-8 Stainless Steel Spacing Stud 3/8-16 x 2 inch L O-ail Length	18-8 Stainless Steel Spacing Stud 3/8"-1.6 Sz, 2" L O-ail, 1" & 5/8" Thread Lengths - McMaster Carr P/N 92997A362 or equivalent	12
15	91306A384	Button Head Socket Cap Screw 1/4"-20 Thread, 1-1/2" Length - McMaster Carr P/N - 91306A384 or equivalent	1
16	Preferred Wide FW 0.25		1
17	92620A540	Grade 8 Alloy Steel Hex Head Cap Screw, 1/4"-20 Thrd, 3/4" L Fully Thrd - McMaster Carr P/N - 92620A540 or equivalent	1
18	90145A509	18-8 Stainless Steel Dowel Pin 3/16" Diameter, 7/8" Length - McMaster P/N - 90145A509 or equivalent	1
19	Dowel Pin - lin - 97395A491	Dowel Pin McMaster Carr P/N - 97395A491 or equivalent	6
20	Silicone O-Ring AS568A Dash Number 263	Silicone O-Ring AS568A Dash Number 263 - McMaster Carr P/N - 9396K255 or equivalent	1
21	Silicone O-Ring AS568A Dash Number 266	Silicone O-Ring AS568A Dash Number 266 - McMaster Carr P/N - 9396K258 or equivalent	2

TOP VIEW
 SCALE: 1:1.5

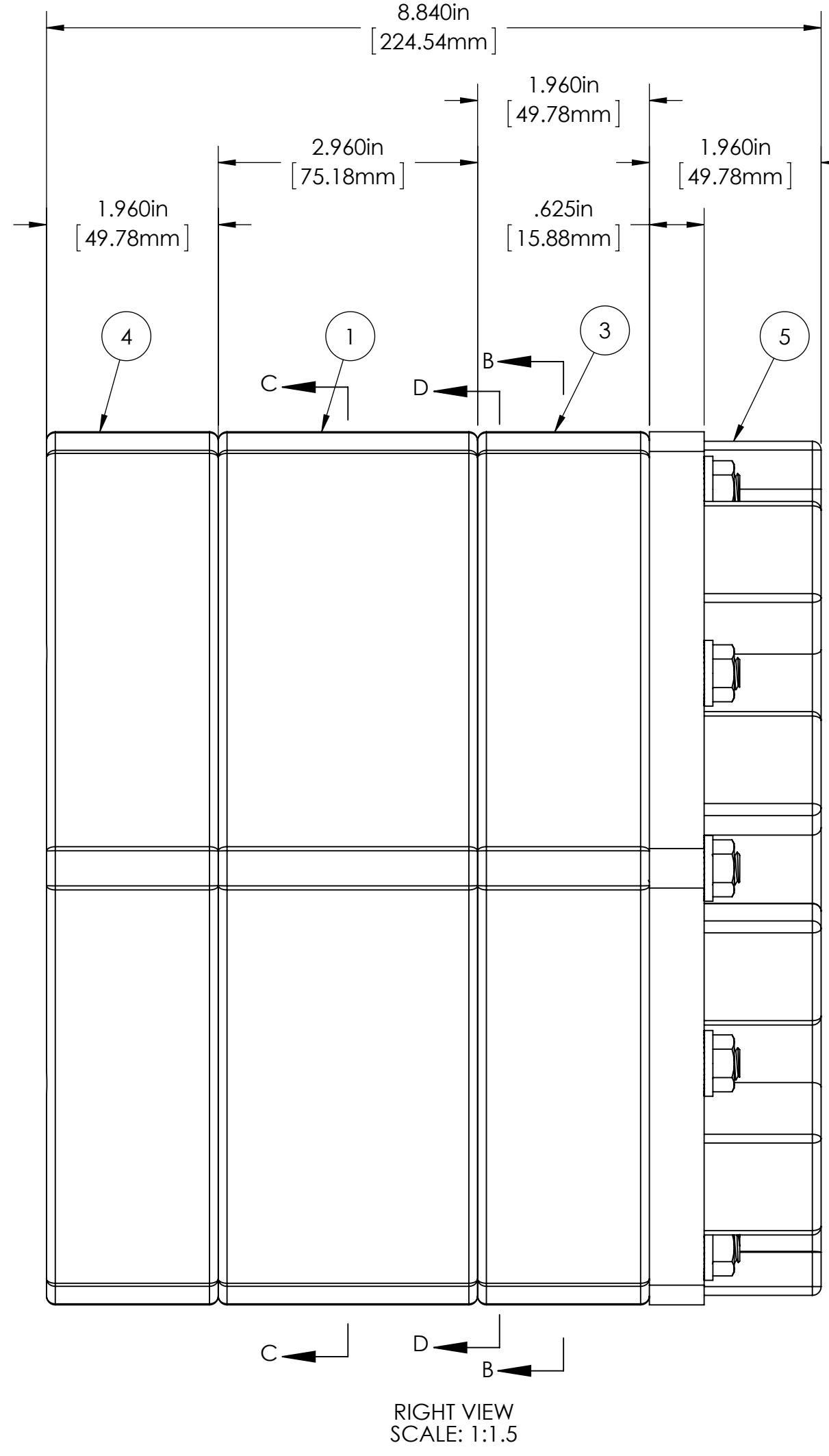

RIGHT VIEW
 SCALE: 1:1.5

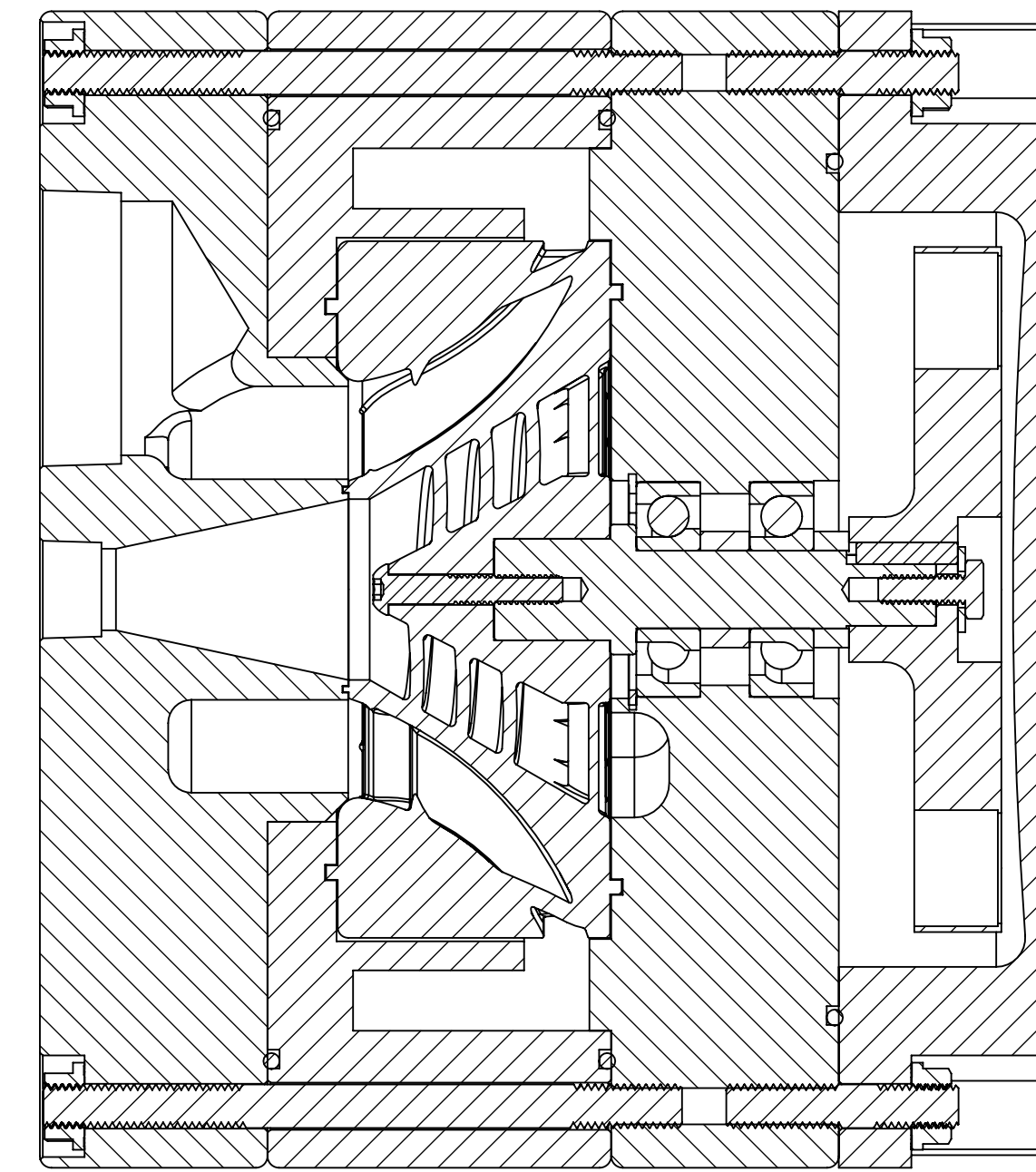

SECTION AA-AA
 SCALE 1:1.5

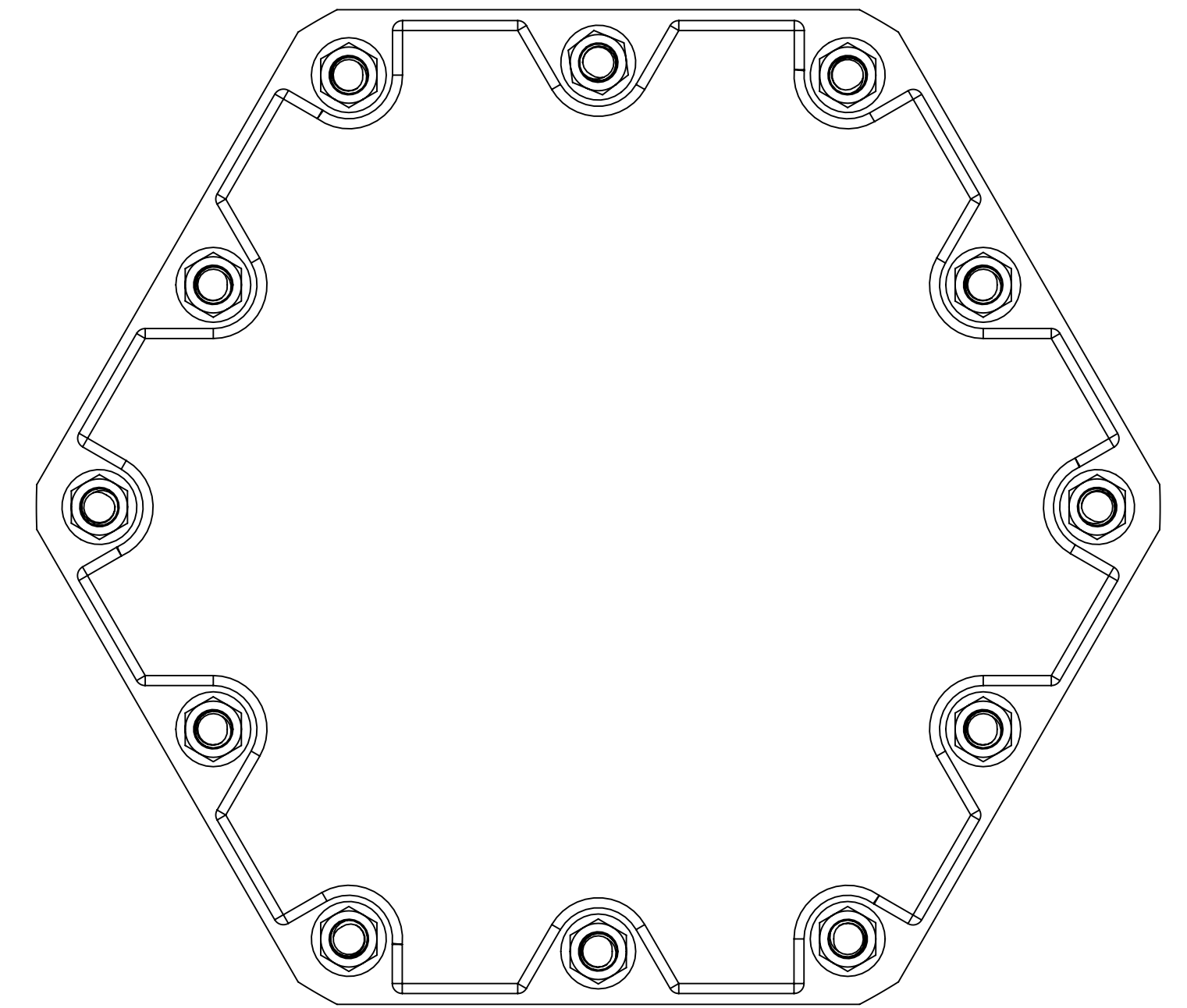

BACK VIEW
 SCALE: 1:1.5

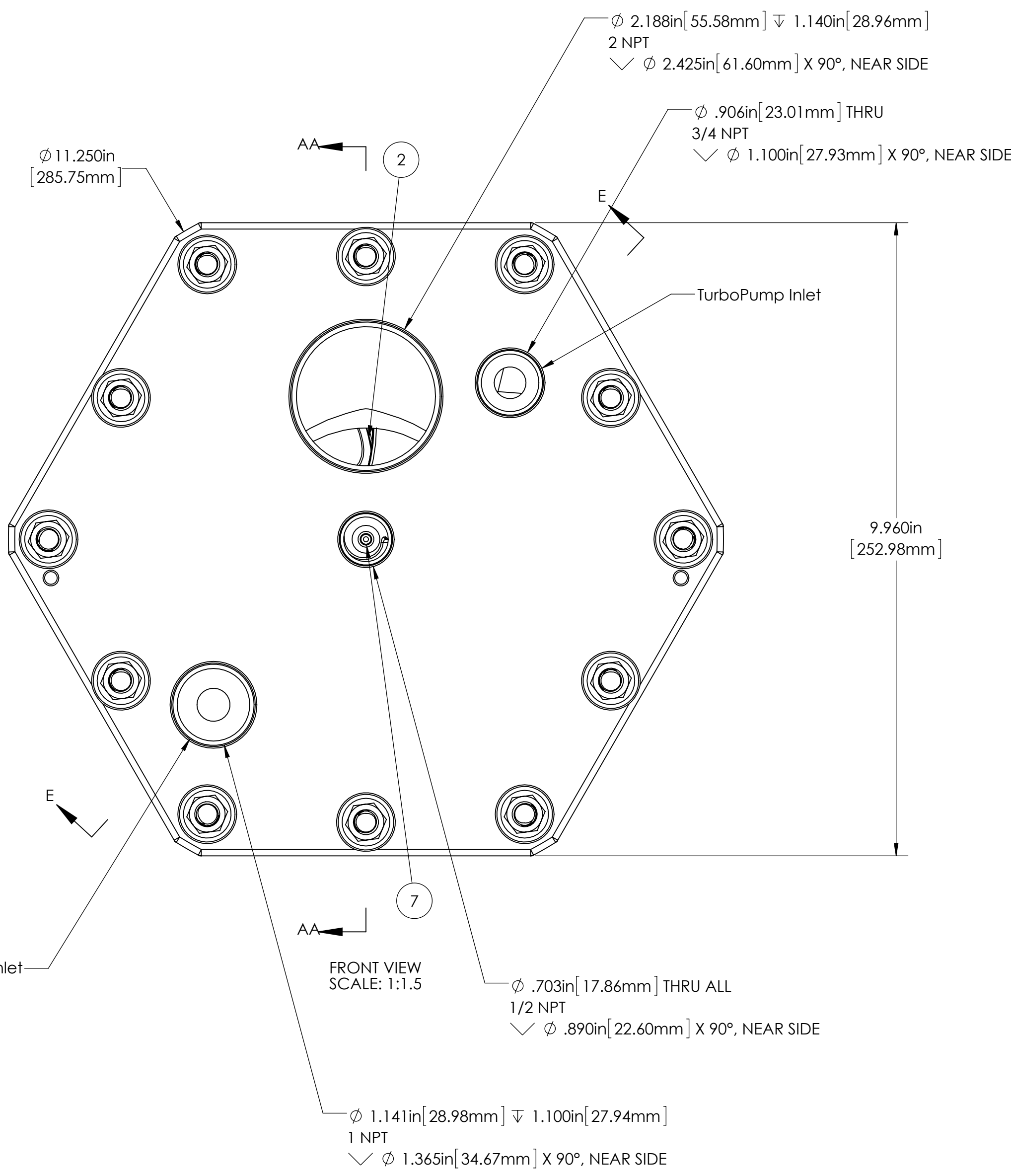

FRONT VIEW
 SCALE: 1:1.5

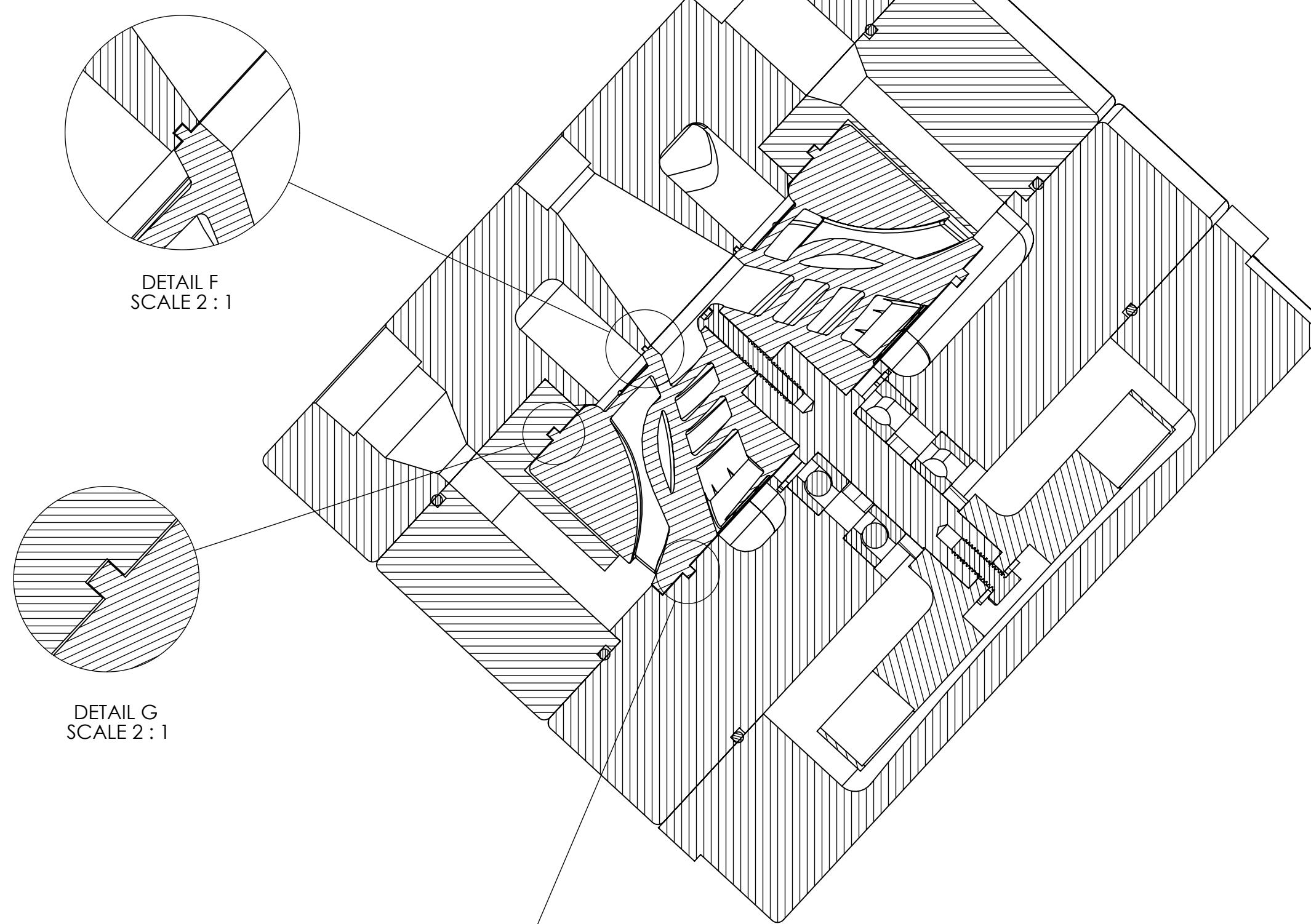

SECTION E-E
 SCALE 1:1.5

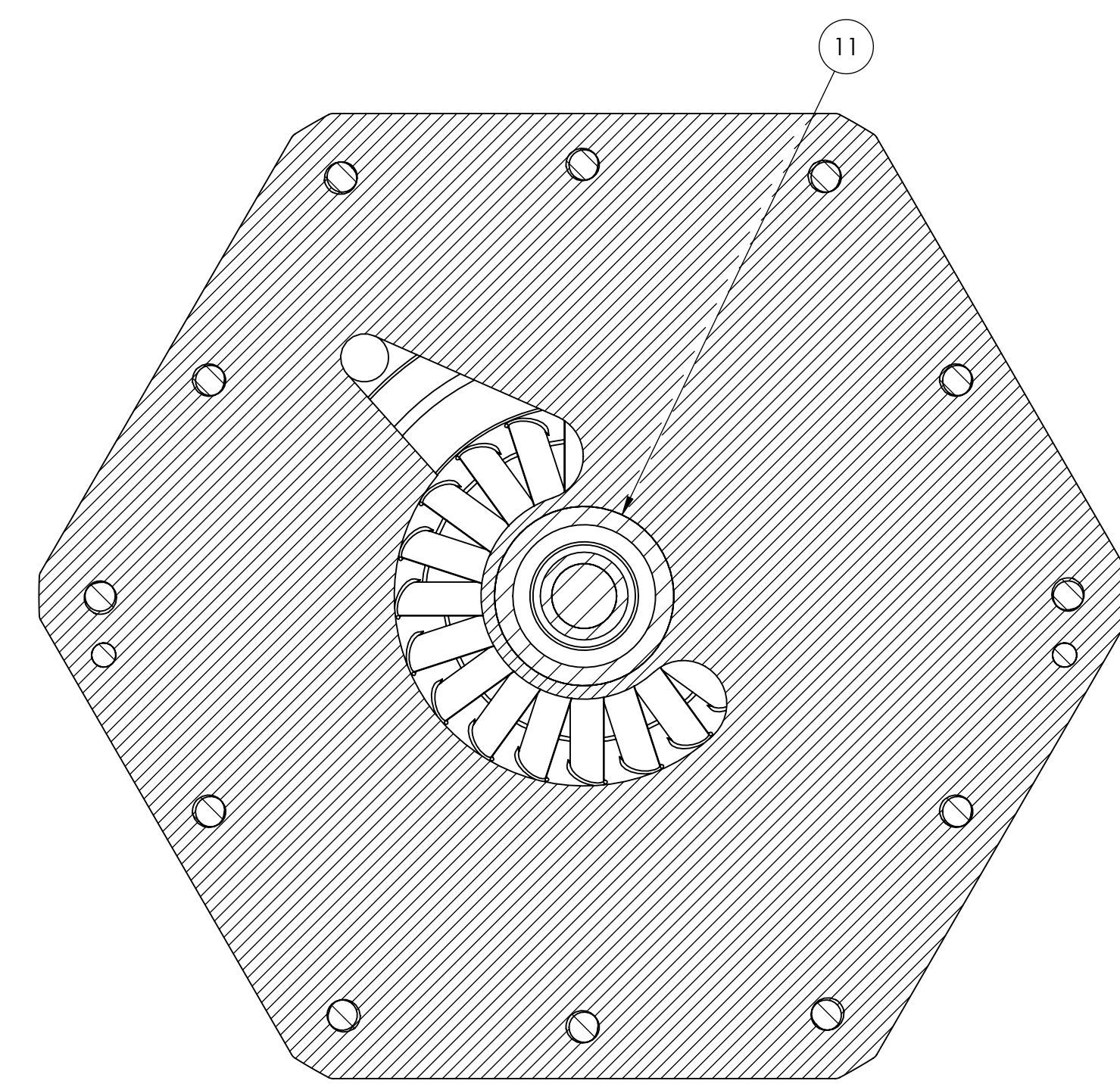

SECTION D-D
 SCALE 1:1.5

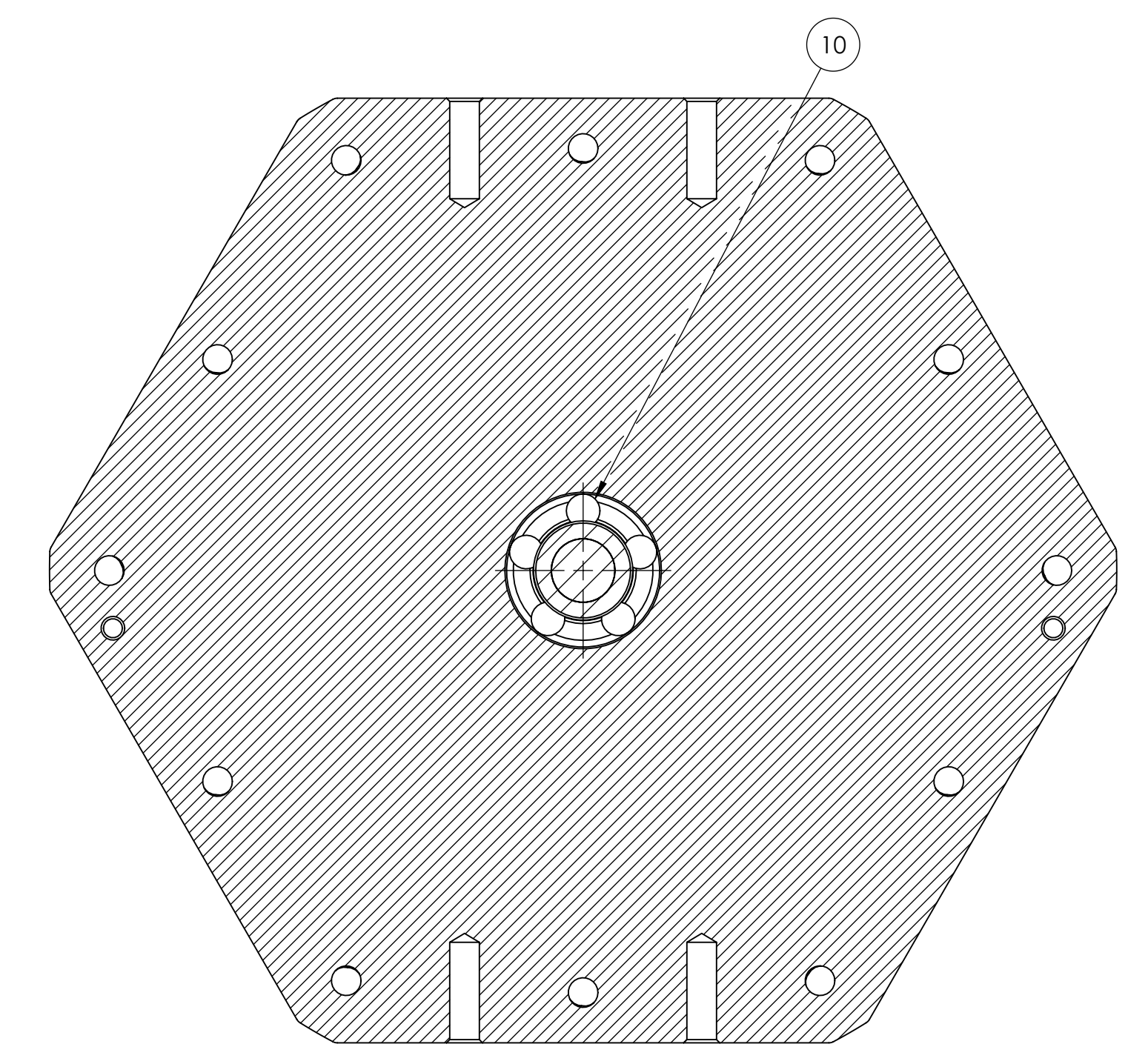

SECTION B-B
 SCALE 1:1.5

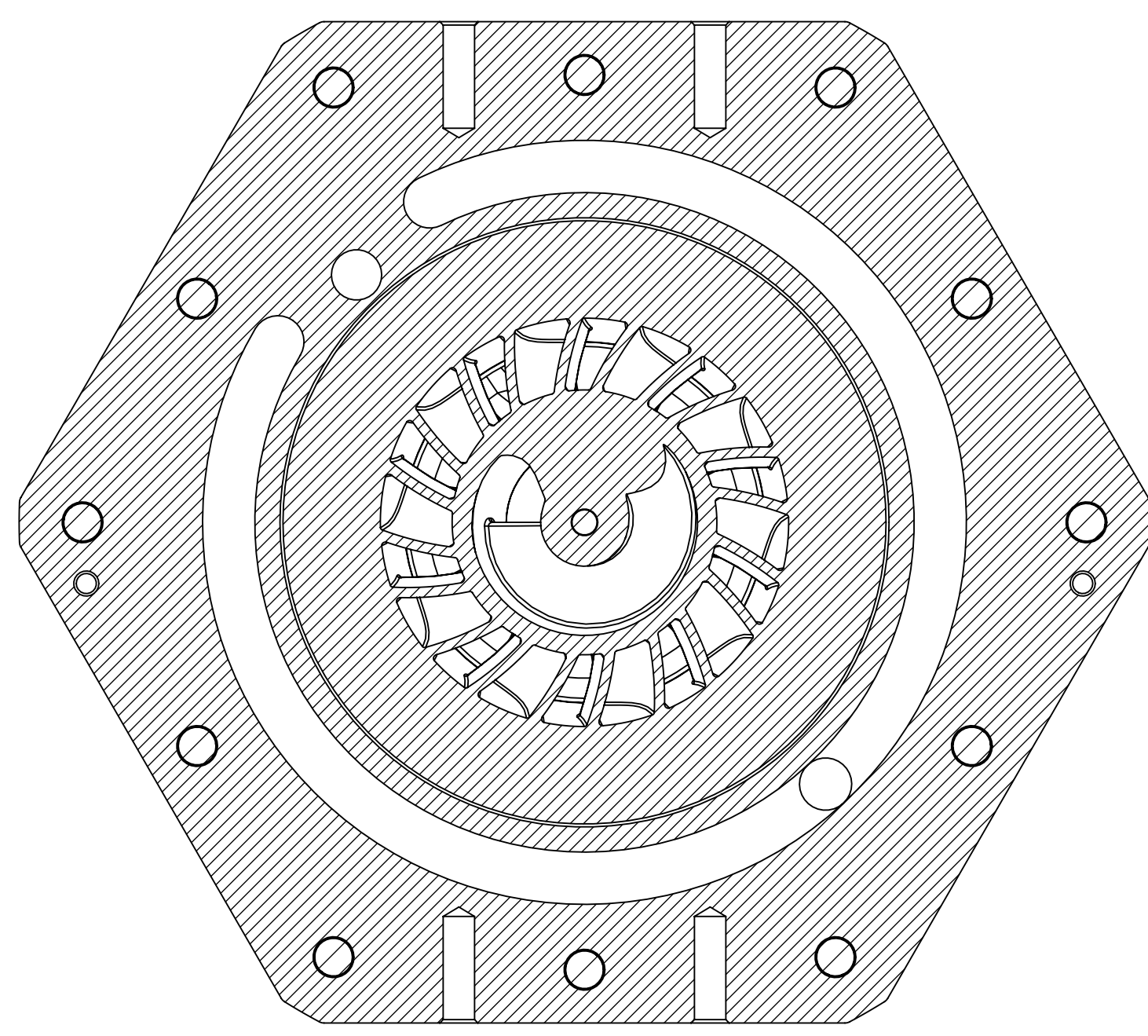

SECTION C-C
 SCALE 1:1.5

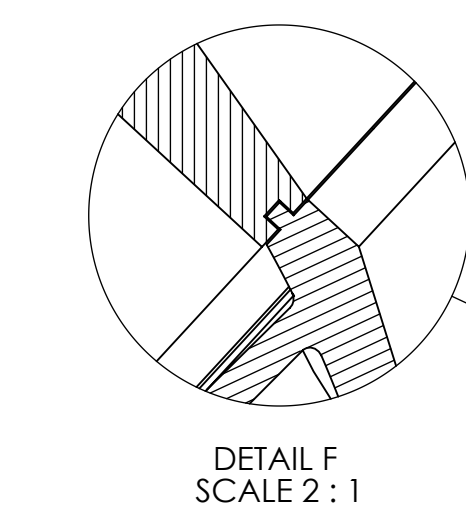

DETAIL F
 SCALE 2:1

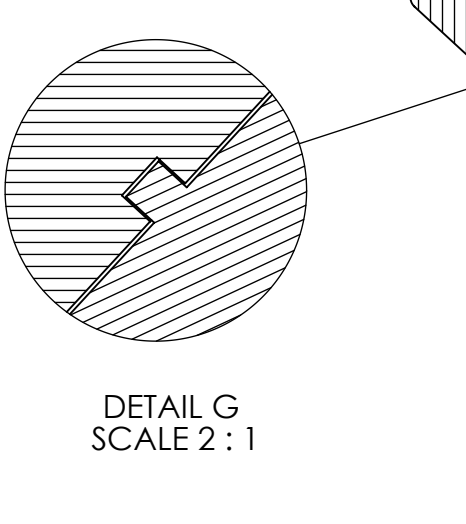

DETAIL G
 SCALE 2:1

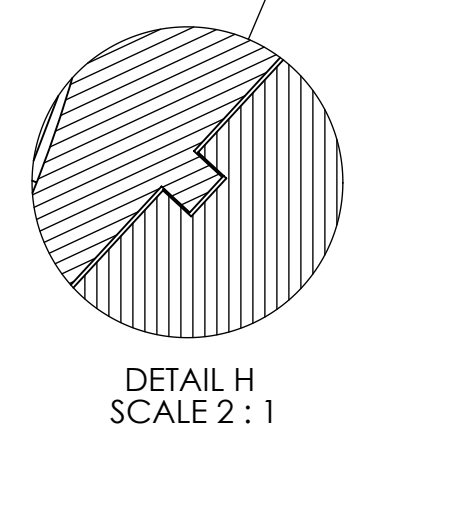

DETAIL H
 SCALE 2:1

PROFESSIONAL AND CONFIDENTIAL
 THE INFORMATION CONTAINED IN THIS DRAWING IS THE SOLE PROPERTY OF INFINITY TURBINE, LLC. ANY REPRODUCTION IN PART OR AS A WHOLE WITHOUT THE WRITTEN PERMISSION OF INFINITY TURBINE, LLC IS PROHIBITED.

UNLESS OTHERWISE SPECIFIED		NAME	DATE
DRAWN	ES/SP		02/20/2013
CHECKED			
ENG APPR			
DATE			
COMMENTS			

Copyright 2013 - Infinity Turbine, LLC - Turbine/Housing Covered Under Patents: 7146999, 7726331

INFINITY TURBINE

2013 ITR

SHEET 1 OF 1